

Traditional Juliet Balcony 1 system handrail with bar

PAGE 1 (ref: JULB1WB100417)

Structural Calculations for Traditional Juliet balconies using BALCONY 1 System handrail (70mm Diameter) AKA "Hybrid Orbit" with 58 x 4mm internal reinforcing bar

Our ref: JULB1WB100417

Date of issue: April 2017



Traditional Juliet Balconies using Balcony 1 handrail system

DESIGN TO EUROCODES & CURRENT BRITISH STANDARDS

Design standards:

EN 1990	Eurocode 0:	Basis of structural design.
EN 1991	Eurocode 1:	Actions on structures.
EN 1993	Eurocode 3:	Design of steel structures.
EN 1999	Eurocode 9:	Design of aluminium structures.
BS EN 1990:2002 + A1:2005	Eurocode:	UK National annex for Eurocode
BS 6180:2011	British standard:	Barriers in and about buildings.
BS EN 1991-1-1-4:2005 + A1 2010	Eurocode 1	Wind actions on structures

Design loads:

Occupancy class/es for which this design applies (Table 2: BS6180:2011)	=	Domestic and residential activities (i) & (ii) Office and work areas not included elsewhere (iii), (iv) & (v) Areas without obstacles for moving people and not susceptible to overcrowding (viii) & (ix)
Service load on handrail	Q_k	= 0.74 kN/m uniformly distributed line load acting 1100mm above finished floor level. (Table 2: BS6180:2011)
Service load applied to the glass infill	Q_{k1}	= A uniformly distributed load of 1.0 kN/m ²
Point load on glass infill	=	0.50 kN applied to any part of the glass fill panels.

Table 2 Minimum horizontal imposed loads for parapets, barriers and balustrades

Type of occupancy for part of the building or structure	Examples of specific use	Horizontal uniformly distributed line load (kN/m)	Uniformly distributed load applied to the infill (kN/m ²)	A point load applied to part of the infill (kN)
Domestic and residential activities	(i) All areas within or serving exclusively one single family dwelling including stairs, landings, etc. but excluding external balconies and edges of roofs	0.36	0.5	0.25
	(ii) Other residential, i.e. houses of multiple occupancy and balconies, including Juliette balconies and edges of roofs in single family dwellings	0.74	1.0	0.5
Offices and work areas not included elsewhere, including storage areas	(iii) Light access stairs and gangways not more than 600 mm wide	0.22	—	—
	(iv) Light pedestrian traffic routes in industrial and storage buildings except designated escape routes	0.36	0.5	0.25
	(v) Areas not susceptible to overcrowding in office and institutional buildings, also industrial and storage buildings except as given above	0.74	1.0	0.5
Areas where people might congregate	(vi) Areas having fixed seating within 530 mm of the barrier, balustrade or parapet	1.5	1.5	1.5
Areas with tables or fixed seatings	(vii) Restaurants and bars	1.5	1.5	1.5
Areas without obstacles for moving people and not susceptible to overcrowding	(viii) Stairs, landings, corridors, ramps	0.74	1.0	0.5
	(ix) External balconies including Juliette balconies and edges of roofs. Footways and pavements within building curtilage adjacent to basement/sunken areas	0.74	1.0	0.5

© BSI 2011 • 9

Table 2: BS6180:2011

- These imposed loads are considered as three separate load cases. They are not combined.
- Factored loads are used for checking the limit state of static strength of a member.
- The service loads are multiplied by a partial factor for variable action $\gamma_{Q,1}$ of 1.5 to give the ultimate design load for leading variable action.

Deflection:

- All structural members deflect to some extent under load. Service loads are used to calculate deflections.
- The total displacement of any point of a barrier from its original unloaded position under the action of service loads is limited to 25mm.

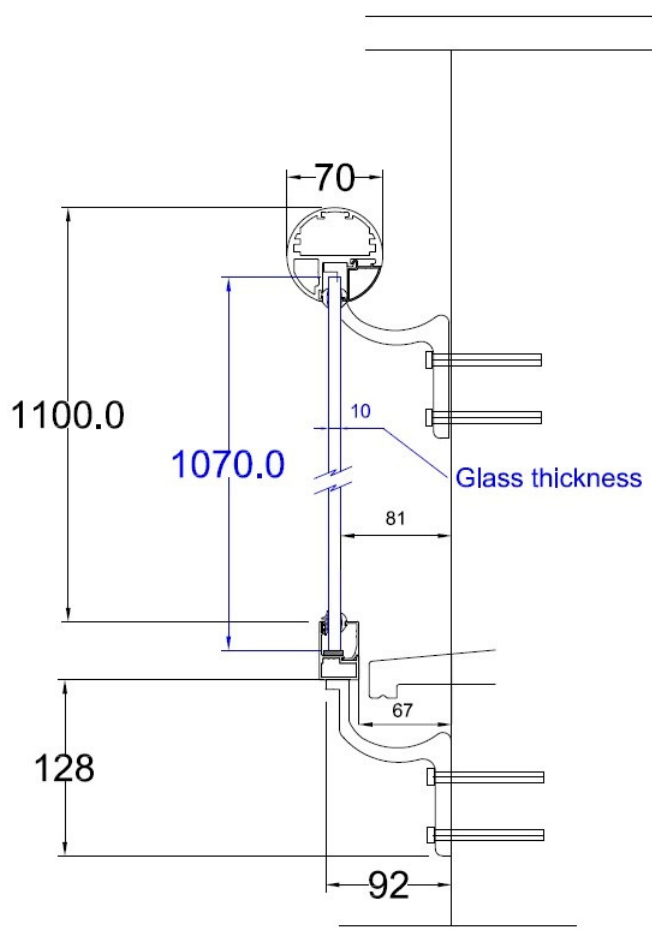
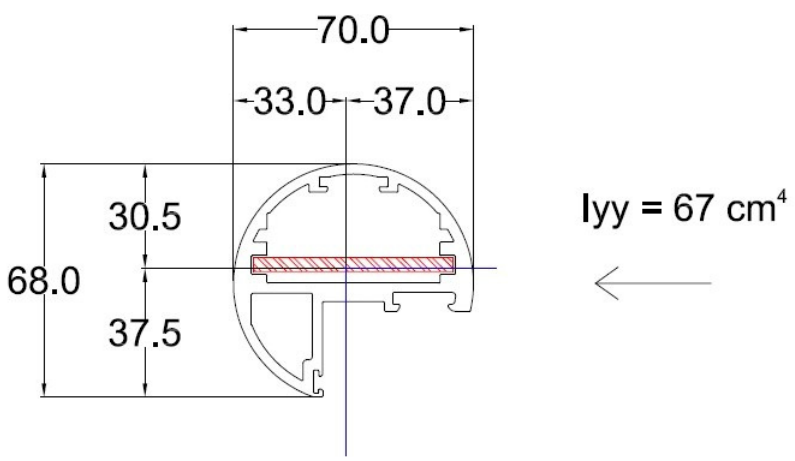

Typical section & handrail profile moment of inertia

Balcony 1 system: Section properties of handrail with internal reinforcing bar:

Material type	=	Extruded aluminium type 6063 T5	
Characteristic 0.2% proof stress	=	f_o	= 130 N/mm ²
Characteristic ultimate tensile strength	=	f_u	= 175 N/mm ²
Modulus of elasticity	=	E	= 70 000 N/mm ²
Shear modulus	=	G	= 27 000 N/mm ²
Moment of inertia about the y-y axis	=	I_{yy}	= 67 cm ⁴
Least elastic modulus about the y-y axis	=	W_{el}	= 17.43 cm ³
Partial factor for material properties	=	γ_{M1}	= 1.10
Value of shape factor (conservative value)	=	α	= W_{pl}/W_{el} = 1.2 say
Design ultimate resistance to bending about the y-y axis	=	M_{Rd}	= $M_{o, Rd}$
	=	$\alpha W_{el} f_o / \gamma_{M1}$	
	=	$\frac{1.2 \times 17.43 \text{ cm}^3 \times 130 \text{ N/mm}^2 \times (10)^{-3}}{1.1}$	
	=	2.472 kNm	

Design ultimate horizontal load on handrail	=	F	=	0.74 kN/m x 1.5
			=	1.11 kN/m
Design horizontal moment on handrail between points of support.	=	M	=	$\frac{F L^2}{8}$
Allowable span L between points of support based upon the moment capacity of the handrail	=		=	$\frac{[8 \times M_{Rd}]^{0.5}}{[F]}$
			=	$\frac{[8 \times 2.472 \text{ kNm}]^{0.5}}{[1.11]}$
			=	4.22m say = 4.00m

In terms of bending capacity the handrail can span up to 4.0m simply supported between points of support.

However the service load deflection is limited to a maximum of 25mm.

The support brackets at each end of the handrail are 80mm wide. For a 3400mm long handrail the span centre to centre of the support brackets is 3320mm.

Deflection (Δ) of span (L) for an imposed UDL (F)	Δ	=	$\frac{5 F L^4}{384 E I}$
For a handrail 3.4m long with the span c/c support brackets 3.32m	Δ	=	$\frac{5 (740 \times 3.32) (3320)^3}{384 \times 70\,000 \times 67 \times (10)^4}$
		=	24.96mm < 25mm OK

Therefore deflection limitations govern the allowable span of the handrail between points of support in respect of the horizontal imposed service uniformly distributed line load.

In order to comply with service load deflection limitations the allowable span of the handrail is limited to **3.32 metres** between the centres of supporting brackets.

Handrail brackets:

The horizontal imposed design load on the handrail can only act over the clear width of the opening, ie. 3140mm for a handrail 3400mm long overall. The bracket design load H is calculated for a maximum loaded length equal to the maximum clear opening width.

For the maximum clear opening width of 3140mm:

Ultimate horizontal imposed load on the handrail bracket	H	=	$(0.74 \text{ kN/m} \times 1.5) \times \frac{3.14}{2}$
		=	1.743 kN

<u>Section (A)</u>	dimensions	=	80mm wide x 12mm thick, less 2 No. 12mm diameter holes for 10mm diameter bolts.
		=	56 x 12mm effective section.

Plastic section modulus	W_{pl}	=	$\frac{56 \times (12)^2}{4}$
		=	2016 mm ³

Handrail Brackets

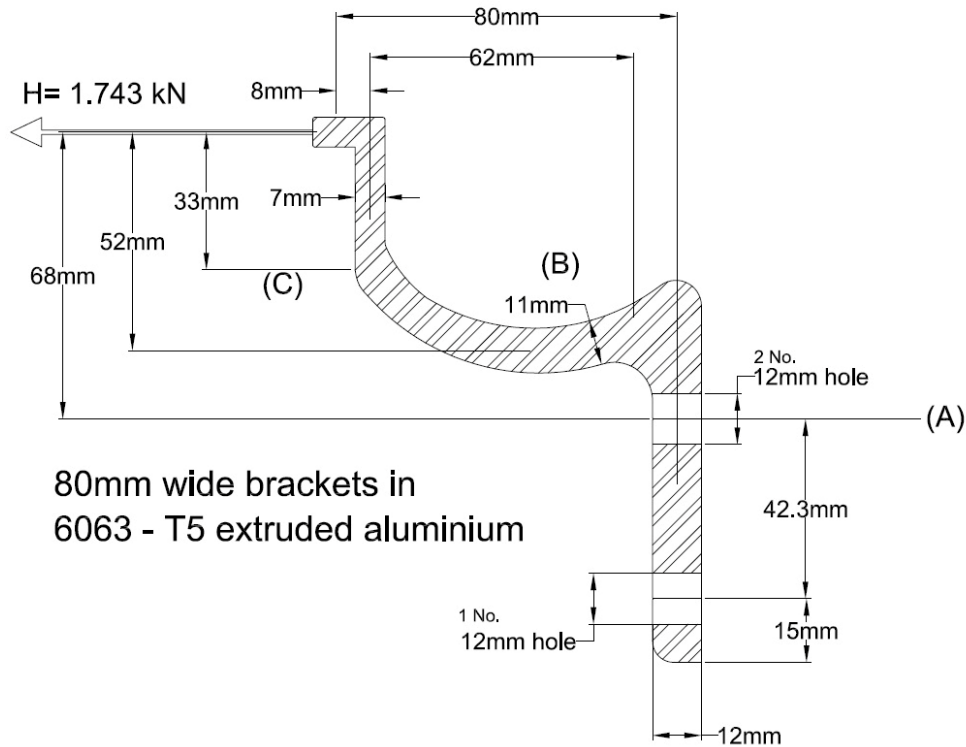

Bracket section (A)

Factored applied moment	M	=	1.743 kN x 0.068		
		=	0.119 kNm		
Limiting stress in bending	f_o	=	130 N/mm ²		
Moment capacity of section	M_c	=	$\frac{130 \text{ N/mm}^2 \times 2016 \text{ mm}^3 \times (10)^{-6}}{1.1}$		
		=	0.238 kNm	>	0.119 kNm OK

Section (B)

Dimensions at section (B)		=	80 mm wide x 11mm thick		
Factored applied moment	M	=	1.743 kN x 0.052		
		=	0.091 kNm		
Plastic section modulus	W_{pl}	=	$\frac{80 \times (11)^2}{4}$		
		=	2420 mm ³		
Moment capacity of section	M_c	=	$\frac{130 \text{ N/mm}^2 \times 2420 \text{ mm}^3 \times (10)^{-6}}{1.1}$		
		=	0.286 kNm	>	0.091 kNm OK

Handrail brackets:

Section (C)

Dimensions of section		=	80 mm wide x 7mm thick	
Factored applied moment	M	=	1.743 kN x 0.033	
		=	0.058 kNm	
Plastic section modulus	W_{pl}	=	$\frac{80 \times (7)^2}{4}$	
		=	980 mm ³	
Moment capacity of section	M_c	=	$\frac{130 \text{ N/mm}^2 \times 980 \text{ mm}^3 \times (10)^{-6}}{1.1}$	
		=	0.116 kNm	> 0.058 kNm OK
<u>Shear force</u> at section (C)	V	=	1.743 kN	
Design plastic shear resistance	$V_{pl, RD}$	=	$\frac{A_v (f_v / \sqrt{3})}{\gamma_{MO}}$	
		=	$\frac{(80 \times 7) (190 / 1.732) \times (10)^{-3}}{1.0}$	
		=	61.43 kN	> 1.743 kN OK

The handrail brackets are adequate to resist the ultimate design bending and shear forces in respect of the maximum handrail span of 3.32 metres between bracket centres.

Handrail bracket fixing bolt forces: (2 No. M10 bolts top; 1 No. M10 bolt bottom of bracket).

Moments taken about the lower bolt for the direct pull-out force on the top 2 No. bolts:

Consider the maximum span c/c brackets of 3.12 m (loaded length of handrail 2.94 m)

Factored load on bracket	H	=	1.743 kN	
Direct tension on top 2 bolts	T	=	$\frac{1.743 \times 0.113}{0.0423}$	= 4.66 kN
		=	2.33 kN/bolt	(ultimate load)
		=	1.55 kN/bolt	(working load)

BS 6180:2011, section 6.5, recommends that barrier fixings, attachments and anchorages should be designed to withstand a greater load than the design loading for the barrier generally. This is intended to ensure that under an extreme load condition, barriers show indications of distress by distortion, before there is any possibility of sudden collapse due to failure of the fixings. A 50% increase in the design load on fixings is recommended.

Applying the above recommendation, the **ultimate** direct pull-out force on the upper bolts becomes 2.33 x 1.5 = **3.50 kN/bolt**. The **working** load pull-out force on the upper bolts becomes 1.55 kN x 1.5 = **2.33 kN/bolt**.

The nominal tension capacity of M10 (8.8 grade) bolts is greater than these design forces. The allowable load is therefore determined by the pull-out resistance of the drilled resin anchor bolts or similar, and also by the strength of the structure into which they are installed to support these loads, and not by the tension capacity of the bolts themselves.

Handrail brackets: working loads on fixing bolts:

For shorter standard length handrails the pull-out forces on bracket fixing bolts are proportionally lower.

Handrail length	opening size	working load tension on each upper bolt (including 50% increase recommended in BS 6180)
1280mm	1020mm	0.76 kN
1500mm	1240mm	0.92 kN
1680mm	1420mm	1.05 kN
1860mm	1600mm	1.19 kN
2180mm	1920mm	1.42 kN
2450mm	2190mm	1.62 kN
2840mm	2580mm	1.91 kN
3200mm	2940mm	2.18 kN

Lower rail brackets: These brackets have the same sectional profile as the handrail brackets but are 40mm wide rather than 80mm. 1 No. 12mm diameter hole is provided top and bottom for M10 bolts, making the effective width of the vertical leg 28mm. The section modulus and moment capacity of the brackets is therefore half that of the handrail brackets. The brackets are installed at 500mm nominal maximum centres. The brackets support the dead load from the glass and rails.

$$\begin{aligned} \text{Dead load from glass + rails} &= 0.26 \text{ kN/m} \times 1.35 (\gamma) = 0.351 \text{ kN/m factored} \\ \text{Factored vertical load per bracket at 500mm centres.} &= 0.351 / 2 = 0.176 \text{ kN/bracket} \end{aligned}$$

Factored moments:

Section (A)	M	=	0.176 kN x 0.08	=	0.0141 kNm	
	M _c	=	0.238 kNm / 2	=	0.119 kNm	OK
Section (B)	M	=	0.176 kN x 0.07	=	0.0123 kNm	
	M _c	=	0.286 kNm / 2	=	0.143 kNm	OK
Section (C)	M	=	0.176 kN x 0.008	=	0.0014 kNm	
	M _c	=	0.116 kNm / 2	=	0.058 kNm	OK

The brackets are adequate to resist the design factored moments.

Bolt loads: (1 No. 10mm diameter bolt top and bottom of bracket)

$$\text{Direct tension on top bolt (factored load)} \quad T = \frac{0.176 \text{ kN} \times 0.086}{0.0423} = 0.36 \text{ kN}$$

Applying the 50% increase in fixing loads recommended in BS 6180, this becomes **0.54 kN/bolt** (ultimate load) and **0.36 kN/bolt** (working load).

$$\text{Shear force: on 2 No. bolts} = \frac{0.176 \text{ kN}}{2} = 0.09 \text{ kN/bolt say}$$

Applying the 50% increase as per BS 6180, this becomes **0.135 kN/bolt** (ultimate load) and **0.09 kN/bolt** (working load).

Glass infill:

Design standard = Institution of Structural Engineers publication *Structural use of glass in building (second edition) February 2014.*

Glass type = 10mm thermally toughened soda silicate safety glass with smooth 'as produced' finish with polished edges.

Characteristic design strength = 120 N/mm²

Ultimate design stress $f_{g;d}$ = $\frac{K_{mod} \times K_{sp} \times K_{g;k}}{\gamma_{M;A}}$ + $\frac{K_v (f_{b;k} - f_{g;k})}{\gamma_{M;V}}$

where:

K_{mod} = 30 second load duration factor
 = 0.89 for a domestic balustrade load

K_{sp} = glass surface profile factor
 = 1.0 for float glass 'as produced'

$f_{g;k}$ = characteristic strength of basic annealed glass
 = 45 N/mm²

K_v = manufacturing process strengthening factor
 = 1.0 for horizontal toughening

$f_{b;k}$ = characteristic strength of processed glass
 = 120 N/mm²

$\gamma_{M;A}$ = material partial factor
 = 1.6 for basic annealed glass

$\gamma_{M;V}$ = material partial factor
 = 1.2 for surface prestressed (toughened) glass

Ultimate design stress $f_{g;d}$ = $\frac{0.89 \times 1.0 \times 45}{1.6}$ + $\frac{1.0 (120 - 45)}{1.2}$
 = **87.53 N/mm²**

Section modulus of glass 10mm thick Z = $\frac{1000 \times (10)^2}{6}$ = 16667 mm³/m

Ultimate moment capacity of glass 1000mm wide x 10mm thick M_u = $f_{g;d} \times Z$
 = 87.53 N/mm² x 16667mm³ x (10)⁻⁶
 = **1.459 kNm/m**

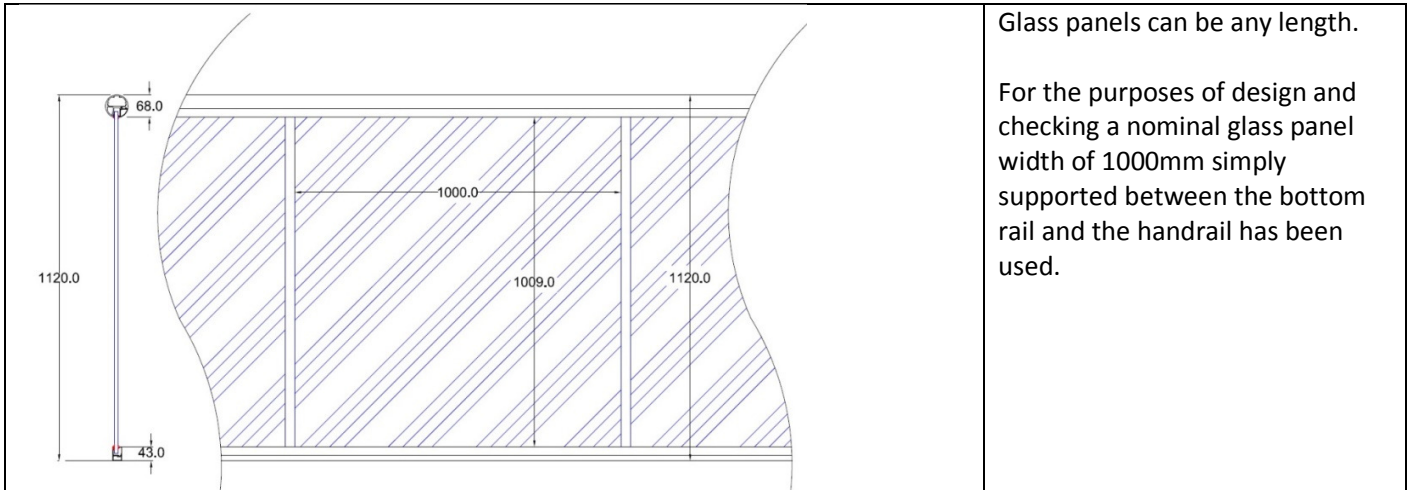

Two separate design conditions are considered:

Uniformly distributed service load on the infill of 1.0 kN/m²

Ultimate UDL on glass	=	1.0 kN/m ² x 1.5	=	1.5 kN/m ²
Ultimate moment on glass due to UDL on 1.0m span	=	$\frac{1.5 \text{ kN/m}^2 \times (1.0)^2}{8}$	=	0.1875 kNm/m
	=	< 1.459 kNm/m	=	OK

The reaction on the handrail from the UDL on the glass is less than the design horizontal UDL on the handrail. Therefore the design load on the glass is not a critical design case in terms of the handrail.

Service point load of 0.5 kN applied in any position on the glass

Worst case for bending stress occurs when the point load is applied at mid-height of the glass.

Ultimate moment on glass due to point load	=	$\frac{(0.50 \text{ kN} \times 1.5) \times 1.0\text{m}}{4}$	=	0.1875 kNm
--	---	---	---	------------

Conservatively, it is assumed that this bending moment is carried by a 300mm wide vertical strip of glass.

Moment capacity of 300mm strip	=	1.459 kNm x 0.30	=	0.4377 kNm
	=	> 0.1875 kNm	=	OK

Glass deflection:

Inertia of glass 1000 x 10mm	=	$1000 \times (10)^3 / 12$	=	83333mm ⁴
------------------------------	---	---------------------------	---	----------------------

Service load deflection due to a UDL of 1.0 kN/m ²	=	$\frac{5 \times (1000 \times 1.0) (1000)^3}{384 \times 70\,000 \times 83333}$	=	2.232mm
	=		=	OK

Inertia of glass 300 x 10mm	=	0.03 x 83333mm ⁴	=	25 000 mm ⁴
-----------------------------	---	-----------------------------	---	------------------------

Service load deflection due a point load of 0.5 kN at mid-span	=	$\frac{500 \times (1000)^3}{48 \times 70\,000 \times 25\,000}$	=	5.95mm
	=		=	OK

The glass is adequate in terms of both bending strength and deflection.



Glass deflection:

Consider service load deflection of the glass due to the design UDL:

$$\begin{aligned} \text{Inertia of glass 10mm thick} &= \frac{1000 \times (10)^3}{12} = 83333 \text{ mm}^4 \\ \text{x 1000mm long} & \\ \\ \text{Service load deflection} &= \frac{5 w L^4}{384 E I} \\ \text{due to a UDL of 1.0 kN/m}^2 & \\ \\ \text{on a simply supported} &= \frac{5 \times (1000 \times 1.0) (1000)^3}{384 \times 70\,000 \times 83333} = 2.232 \text{ mm} \\ \text{span of 1.0m} & \\ \\ &< \frac{\text{span}}{65} = \text{OK} \end{aligned}$$

Conservatively, for deflection calculation purposes consider that the design point load is carried by a 300mm wide vertical strip of glass:

$$\begin{aligned} \text{Inertia of glass 10mm thick} &= 0.3 \times 83333 \text{ mm}^4 = 25\,000 \text{ mm}^4 \\ \text{x 300mm long} & \\ \\ \text{Service load deflection} &= \frac{P L^3}{48 E I} \\ \text{due to a point load of 0.5 kN} & \\ \text{applied at mid-span} &= \frac{500 \times (1000)^3}{48 \times 70\,000 \times 25\,000} \\ &= 5.95\text{mm} \\ &< \frac{\text{span}}{65} = \text{OK} \end{aligned}$$

The glass is adequate in terms of both bending strength and deflection.

Handrail – bracket connection:

The handrail is connected to the wall brackets by means of 2 No. 4.8mm diameter stainless steel self-tapping screws.

The maximum opening size (and therefore maximum loaded length of handrail) is 3.14m.

$$\begin{aligned} \text{Horizontal service (working)} &= 0.74 \text{ kN/m} \times 1.57\text{m} \\ \text{load on the wall fixing for a} &= 1.162 \text{ kN/fixing} \\ \text{clear span of 3.14m} & \\ \\ \text{Working load shear force} &= 1.162 \text{ kN/2} = 0.581 \text{ kN/bolt or screw} \\ \text{on the 4.8mm x 19mm stainless} & \\ \text{steel self-tapping screws} & \\ \\ \text{Ultimate load shear force on} &= 0.581 \text{ kN/bolt} \times 1.5 = 0.8715 \text{ kN/bolt or screw} \\ \text{the anchor bolts and screws} & \end{aligned}$$

Shearing force, construction screws

Dimensioning value F_{sd} kN/screw. Attention is paid both to failure of the edge of the hole and shearing failure in the screw. Safety class 1.

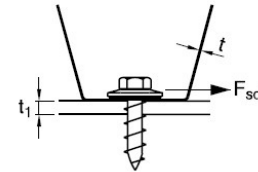

Nom t mm	When calculating t mm	Tensile yield limit N/mm ²	Screw diameter 4.2 mm		Screw diameter 4.8 mm		Screw diameter 5.5 mm		Screw diameter 6.3 mm							
			t ₁ = t	t ₁ = 2.5 t	t ₁ = t	t ₁ = 2.5 t	t ₁ = t	t ₁ = 2.5 t	t ₁ = t	t ₁ = 2.5 t						
0.4	0.32	250	0.26	0.54	0.28	0.61	0.30	0.70	0.32	0.81						
0.5	0.41	250	0.38	0.69	0.40	0.79	0.43	0.90	0.46	1.03						
0.6	0.52	250	0.52	0.86	0.56	0.98	0.60	1.12	0.64	1.29						
0.7	0.60	350	0.93	1.41	1.00	1.61	1.07	1.85	1.14	2.12						
0.8	0.73	350	1.25	1.72	1.34	1.96	1.43	2.25	1.53	2.58						
1.0	0.93	250	1.29	1.56	1.38	1.79	1.47	2.05	1.58	2.34						
1.0	0.93	350	1.80	2.19	1.93	2.50	2.06	2.86	2.21	3.28						
1.2	1.13	350	2.41	2.66	2.58	3.04	2.76	3.48	2.95	3.99						
1.5	1.42	250	2.39	2.39	2.60	2.73	2.78	3.12	2.97	3.58						
1.5	1.42	350	3.03*	3.03*	3.63	3.82	3.64	3.89	4.37	4.16	5.01					
2.0	1.91	350	3.03*	3.03*	4.16	3.64	4.16	3.64	5.72	5.20	5.72	5.20	6.49	6.74		
2.5	2.40	350	3.03*	3.03*	4.16	3.64	4.16	3.64	5.72	5.20	5.72	5.20	7.80	6.76	7.80	6.76

In the area of number pairs in the table and marked *, shearing failure in the screw is decisive.

The value to the left in each number pair relates to carbon steel screws, while the number to the right relates to stainless steel screws.

Excerpt of the table at the foot of page 7 of Lindab's literature headed 'Shearing force, construction screws'

Properties of stainless steel self-tapping screws:

- material type = stainless steel grade 304
- Characteristic ultimate tensile strength = 621 N/mm²
- Characteristic 0.2% proof stress = 290 N/mm²

Phillips self-tapping screws: ultimate shear loads taken from the table in Lindab's technical literature.

Thickness of aluminium in the handrail at screw positions = 5.4mm

Ultimate shear capacity of 4.8mm diameter screws, safety class 1 for Nom t = 2.5mm = 3.64 kN/screw (from Lindab's table)

For safety classes 2 and 3 this value is divided by 1.1 and 1.2 respectively. Safety class 3 is the highest safety class and has been assumed to apply to balustrades. The shear capacities given in Lindab's table are based upon material having a tensile yield limit of 350 N/mm². The values given in the table have been adjusted to allow for the yield stress of stainless steel type 304 (290 N/mm².) The ultimate shear capacity of 3.64 kN/screw has therefore been reduced by 290/350 and divided by 1.2 to represent safety class 3 and 290 N/mm² yield stress rather than 350 N/mm². The adjusted ultimate shear capacity is then 2.51 kN/screw. Exceeds 0.8715 kN/screw and therefore OK

SUMMARY**Traditional Juliet balconies using BALCONY 1 System handrail (70mm Diameter) with 58 x 4mm steel internal reinforcing bar**

1. The Juliet Balconette system, comprising Balcony 1 type handrail (with bar) and bottom rail (no bar) in extruded aluminium grade 6063 T5, in conjunction with 10mm thick toughened glass panels, is adequate to support the imposed loads specified in relevant British and European standards in respect of the occupancy classes listed on page 2, for spans up to **3.32 metres** between the centres of handrail support brackets.
2. The handrail support brackets in extruded aluminium grade 6063 T5 are adequate to support the specified loads for spans up to **3.32 metres** between handrail bracket centres. The bottom rail brackets in extruded aluminium grade 6063 T5 are adequate at up to **500mm** nominal centres between the brackets.
3. For the design loading and 3.32 maximum span between handrail bracket centres, the calculated working load direct pull-out force on each of the top 2 No. bolts on the handrail bracket fixing bolts is **2.33 kN**. For smaller width openings the working load direct pull-out force on the top 2 No. bolts on the handrail brackets are reduced, as listed below:

<u>Handrail length</u>	<u>Opening size</u>	<u>Working load tension on each upper bolt</u> (including 50% increase recommended in BS 6180)
1280mm	1020mm	0.76 kN
1500mm	1240mm	0.92 kN
1680mm	1420mm	1.05 kN
1860mm	1600mm	1.19 kN
2180mm	1920mm	1.42 kN
2450mm	2190mm	1.62 kN
2840mm	2580mm	1.91 kN
3200mm	2940mm	2.18 kN

4. For bottom rail brackets installed at 500mm nominal centres, the calculated working load direct pull-out force on the top bolt is **0.36 kN**, including the 50% increase recommended in BS 6180. The calculated working load shear force on each of the 2 No. fixing bolts **0.09 kN/bolt**.
5. The installers should satisfy themselves that the fixing bolts chosen are suitable to resist the loads specified in items 3 and 4 above, and also that the structure into which they are to be installed can support these loads.
6. The 10mm thick thermally toughened safety glass panels are adequate to support the design loads specified in the relevant British and European Standards.
7. The 4.8mm diameter self-tapping stainless steel screws connecting the handrail to the aluminium wall brackets are adequate to support the design loads specified in relevant British and European Standards.

Prepared for and on behalf of Balconette by
A G Bice CEng FICE FStructE