

SG12 - Frameless Glass Balustrade Installation Guide



Table of contents:

- Pages 1 - 3

SG12 **Above** Finished Floor Level Installation Guide

- Pages 4 - 6

SG12 **Below** Finished Floor Level Installation Guide

- Pages 7 - 8

SG12 Handrail Installation Guide

Before you start:

- Check you have all the parts of the order.
- Check the height of the glass.
- Check that the height of the glass, base channel and handrail (if applicable) conform to the drawings and the required height on site making sure they are correct before assembling.
- Read and understand these instructions before starting installation.

UNLESS OTHERWISE STATED ALL DIMENSIONS IN MILLIMETERS. DO NOT SCALE FROM THIS DRAWING.

BALCONY SYSTEM SOLUTIONS LTD.
UNIT 6 SYSTEMS HOUSE,
EASTBOURNE ROAD,
BLINDLEY HEATH,
SURREY,
RH7 6JP

TEL: 01342 410 411
FAX: 01342 410 412

WWW.BALCONETTE.CO.UK



Hybrid[®]

SG12 Installation Guide Above Finished Floor Level - Wedges

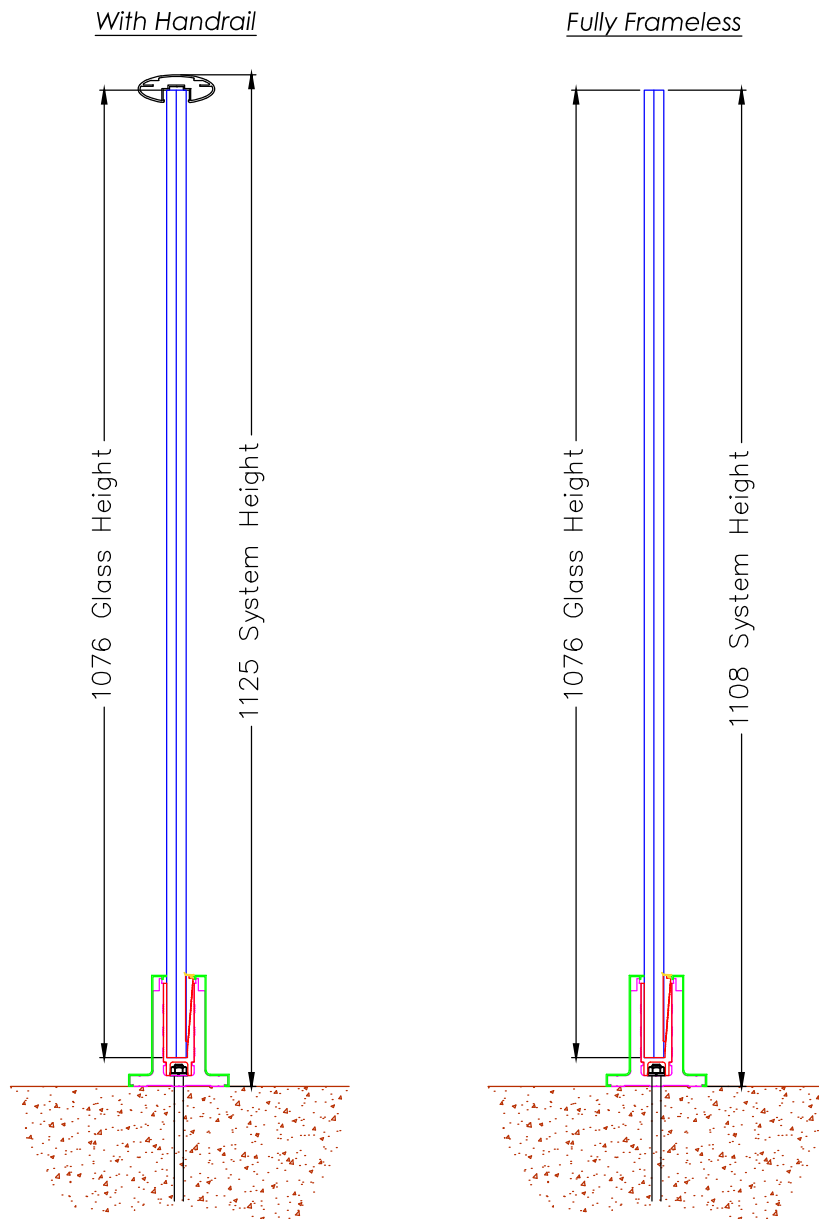

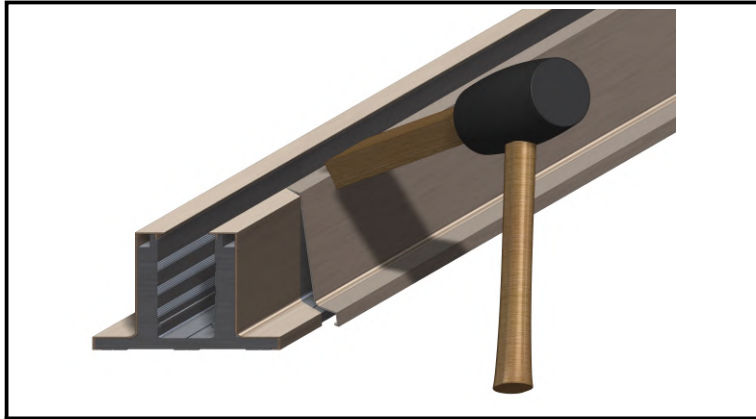

1) Remove the Outer and Internal base track cover profile(s) and keep safely to one side. You can leave the short corner cover plates in position (if applicable). You may need to use a piece of wood and a mallet to unseat the profile.

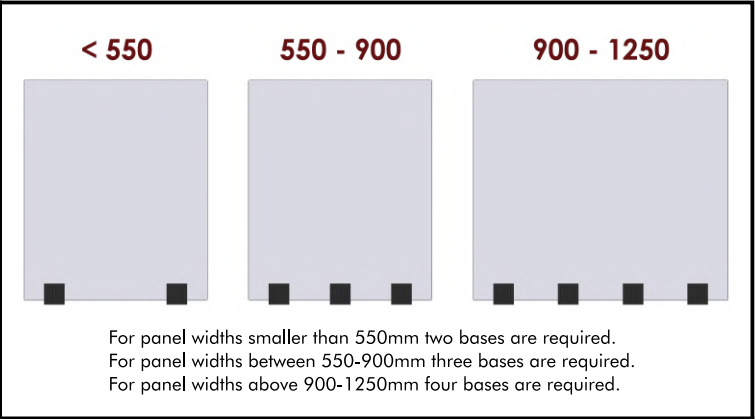

2) Glazing bases in combination with glazing wedges are used to secure the glasses in the base track. Calculate the number of bases required per length of base track.

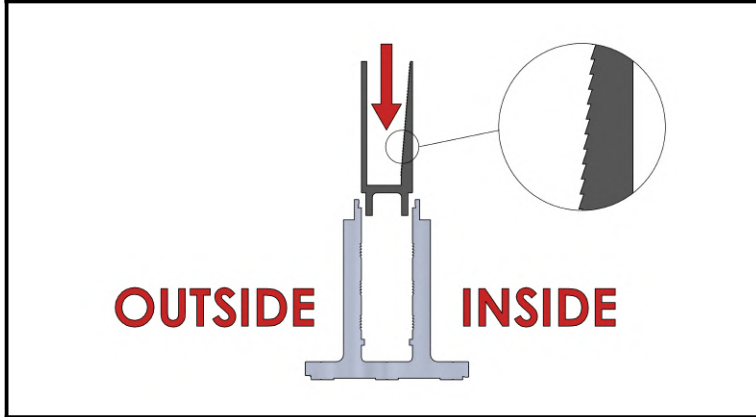

3) Insert the glazing bases where required into the base track section(s) ensuring the tapered side is on the Internal side of the system as shown.

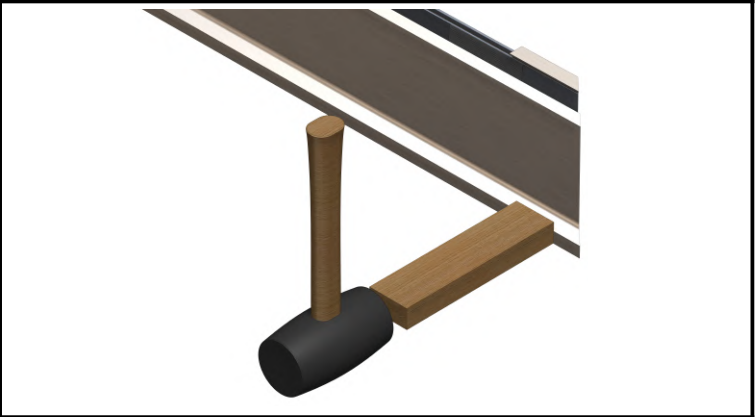

4) Install the outer cover profile, you may need to use a piece of wood and a mallet to seat the profile.

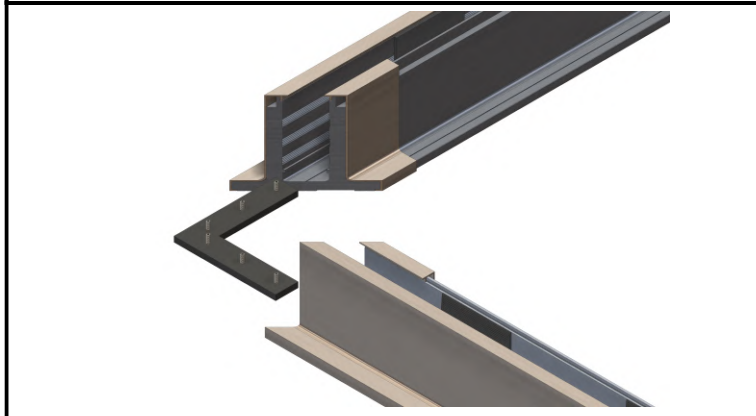

5) Prepare to assemble the base track corners and/or straight joints (if applicable).

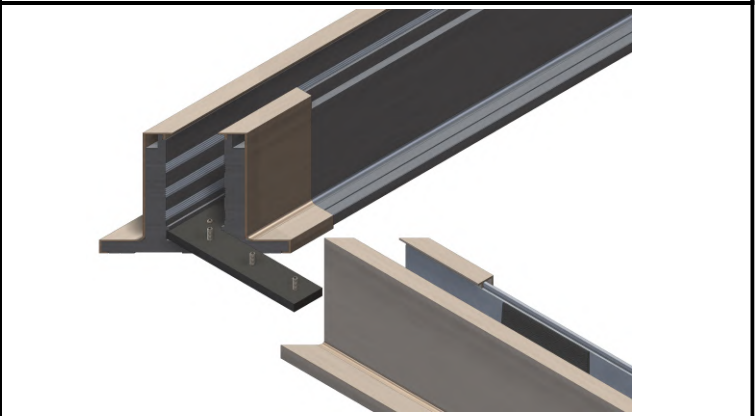

6) Slide the corner bracket into one of the base track sections and tighten the screws.



7) Slide the other side of the base track onto the exposed corner bracket. Hold the corner or join closed and tighten the screws. In this fashion assemble all the base track sections together and ensure the dimensions and shape fit.

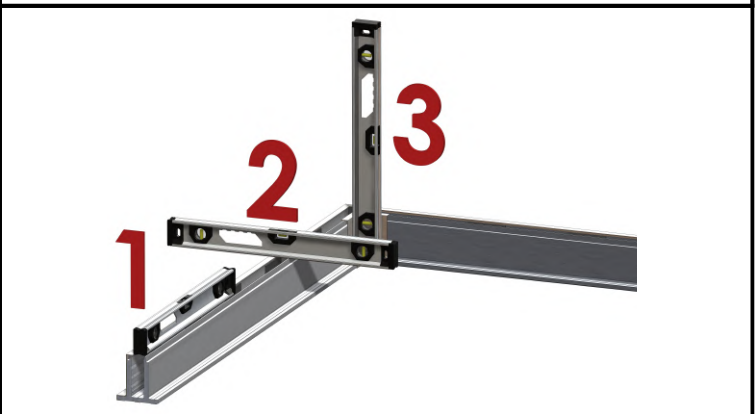

8) Fix the track to the structure with appropriate fixings and level vertically and horizontally.

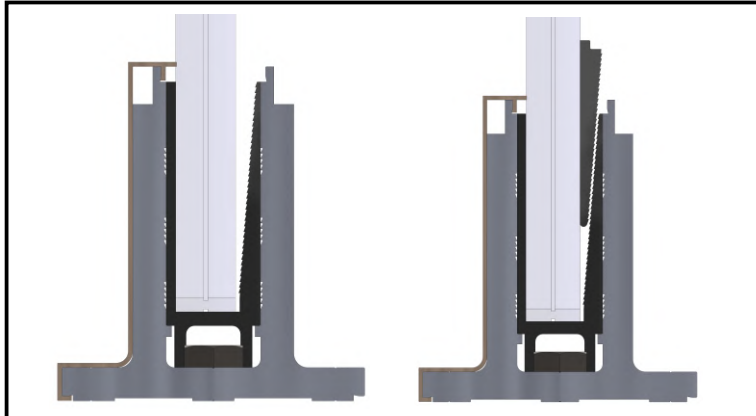

9) Position the glazing bases to receive the first panel and insert the first glass. Insert the glazing wedges by hand to hold the glass.

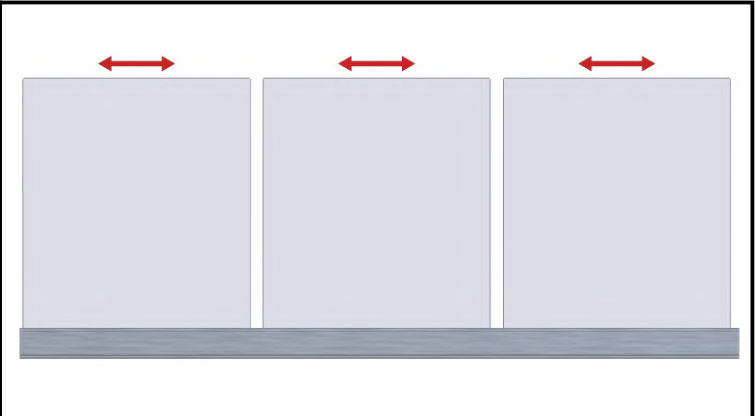

10) In this fashion insert all the glasses into the section(s) of base track and space the glasses evenly or as desired.

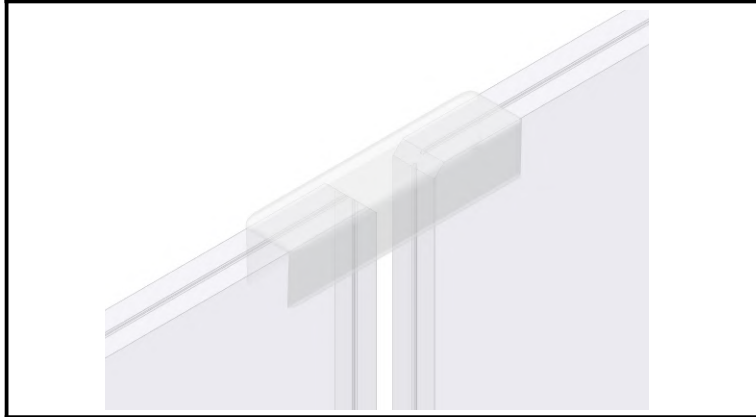

11) Install glass gap bridges between glasses (provided on orders without handrails)

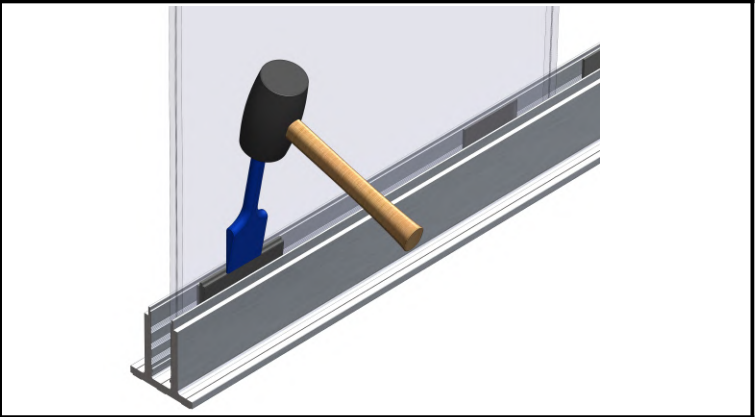

12) Using a glazing shovel and a mallet drive all the glazing wedges into the glazing base to secure the glass solidly in place.

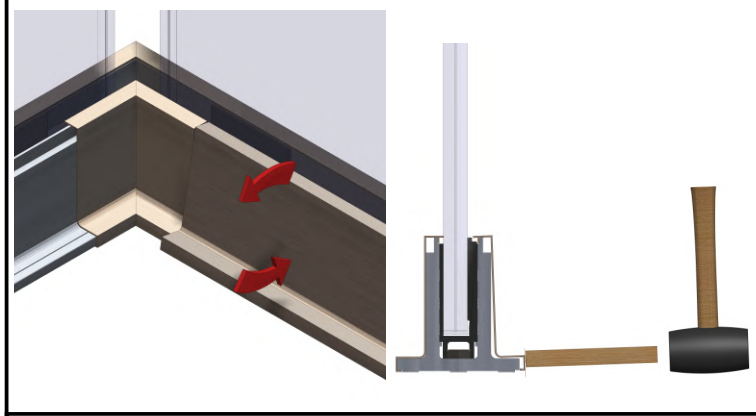

13) Install the Internal cover(s), you may need to use a piece of wood and a mallet to seat the profile.

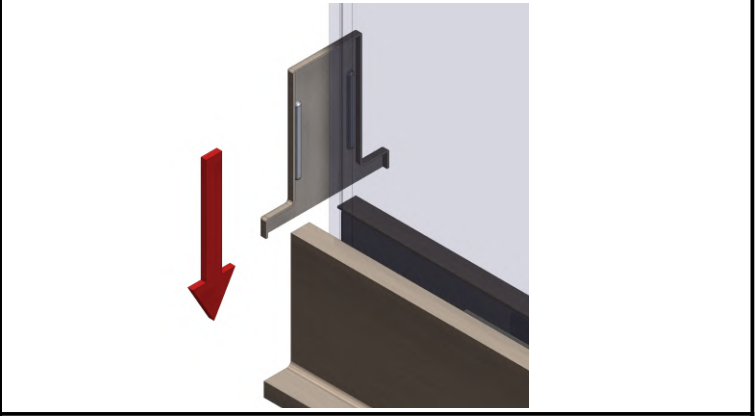

14) Install the end cap.

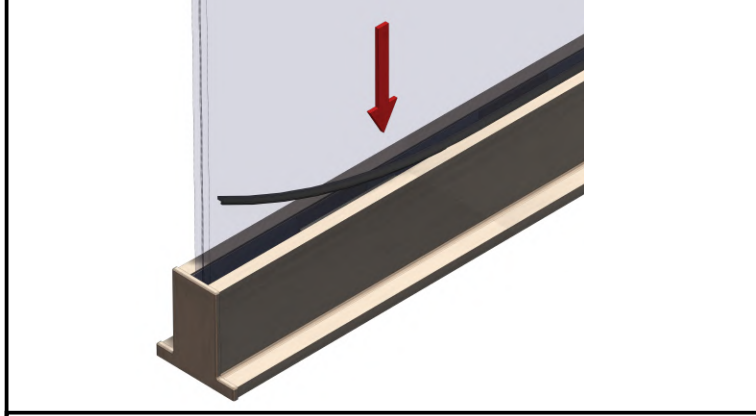

15) Insert gasket between the inside base track cover plate and the glass panels to complete the base track installation.



Hybrid[®]

SG12 Installation Guide Below Finished Floor Level - Wedges

WITH HANDRAIL

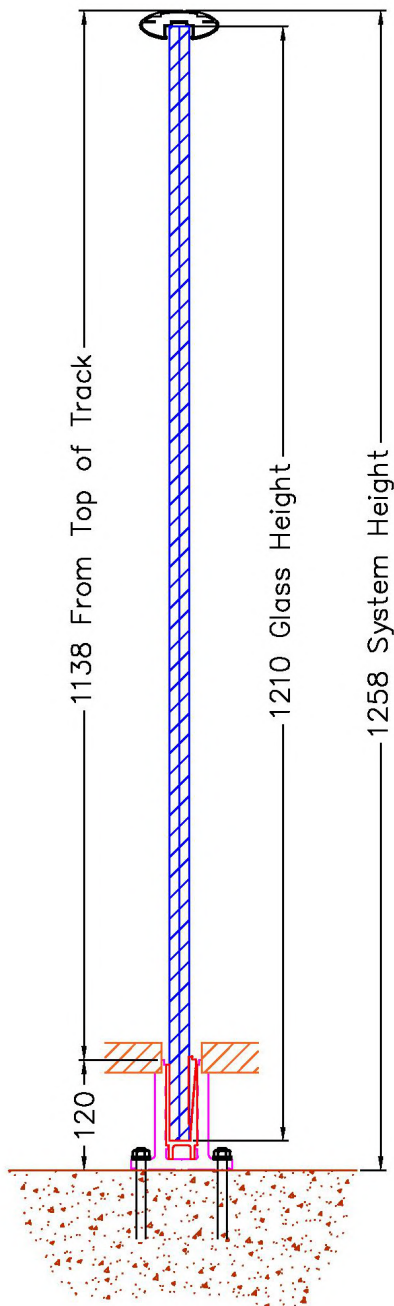

FULLY FRAMELESS

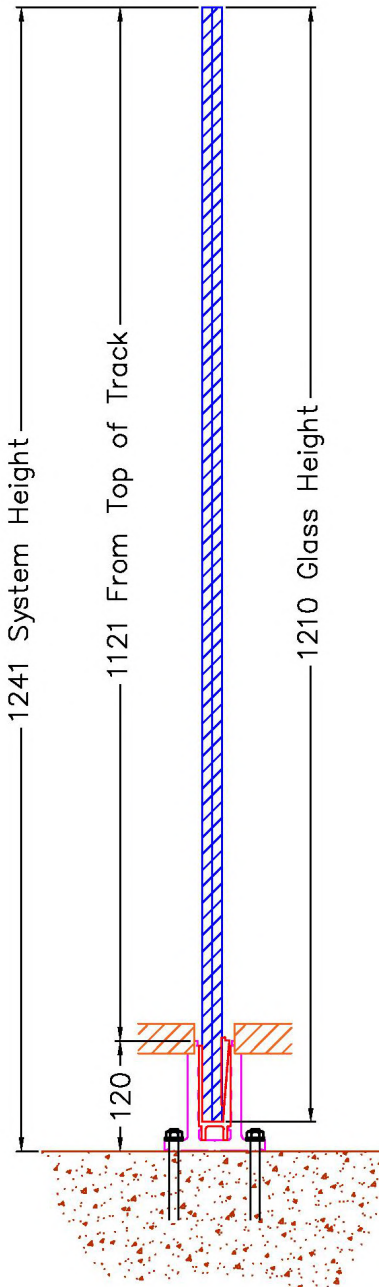

<p>< 550 550 - 900 900 - 1250</p> <p>For panel widths smaller than 550mm two bases are required. For panel widths between 550-900mm three bases are required. For panel widths above 900-1250mm four bases are required.</p>	<p>OUTSIDE INSIDE</p>
<p>1) Glazing bases in combination with glazing wedges are used to secure the glasses in the base track. Calculate the number of bases required per length of base track.</p>	<p>2) Insert the glazing bases where required into the base track section(s) ensuring the tapered side is on the Internal side of the system as shown.</p>
<p>3) Prepare to assemble the base track corners and/or straight joints (if applicable).</p>	<p>4) Slide the corner bracket into one of the base track sections and tighten the screws.</p>
<p>5) Slide the other side of the base track onto the exposed corner bracket. Hold the corner or join closed and tighten the screws. In this fashion assemble all the base track sections together and ensure the dimensions and shape fit.</p>	<p>6) Fix the track to the structure with appropriate fixings and level vertically and horizontally.</p>
<p>7) Position the glazing bases to receive the first panel and insert the first glass. Insert the glazing wedges by hand to hold the glass.</p>	<p>8) In this fashion insert all the glasses into the section(s) of base track and space the glasses evenly or as desired.</p>

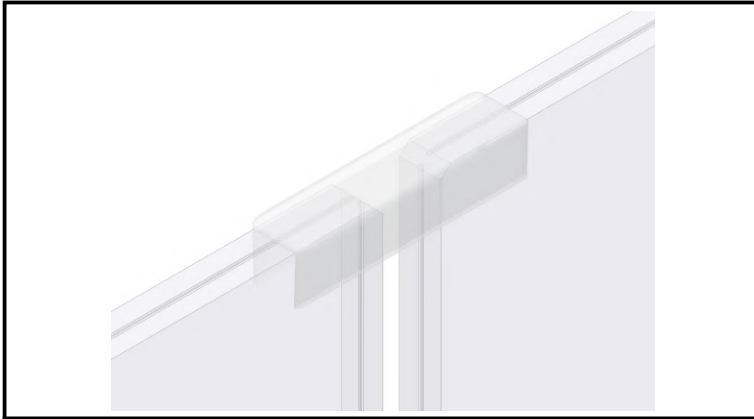

9) Install glass gap bridges between glasses (provided on orders without handrails)

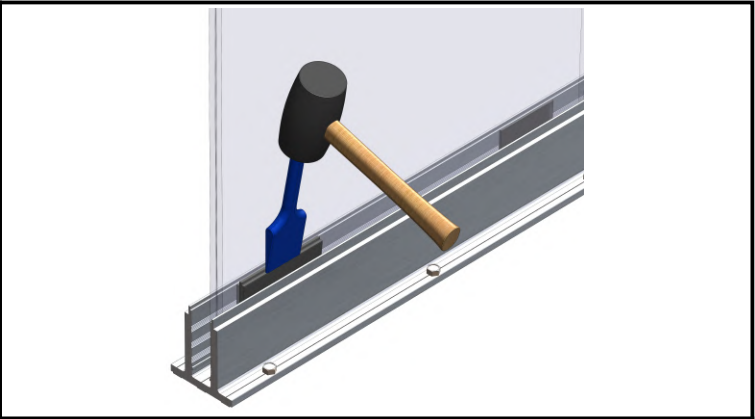

10) Using a glazing shovel and a mallet drive all the glazing wedges into the glazing base to secure the glass solidly in place.

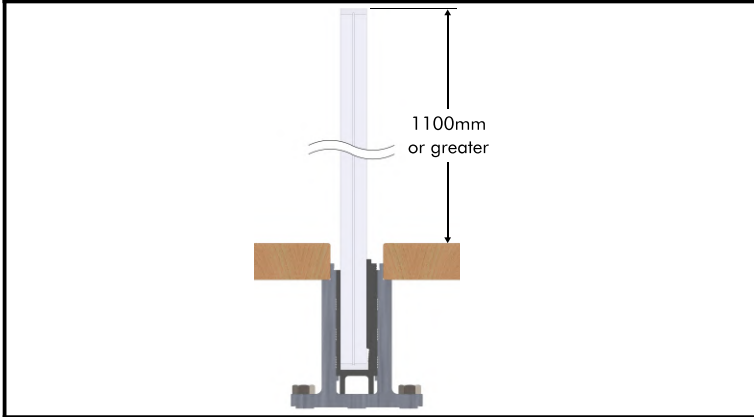

11) Please ensure finished flooring is installed so that the remaining height of the glass/balustrade is not less than 1100mm above Finished floor level.

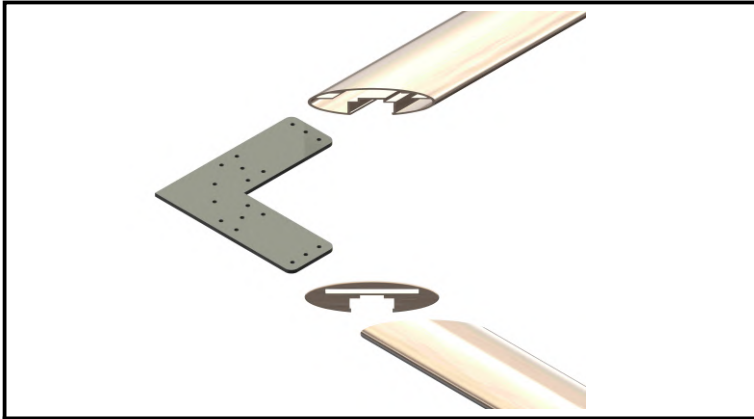

1) Prepare to assemble the handrail corner. (if applicable)

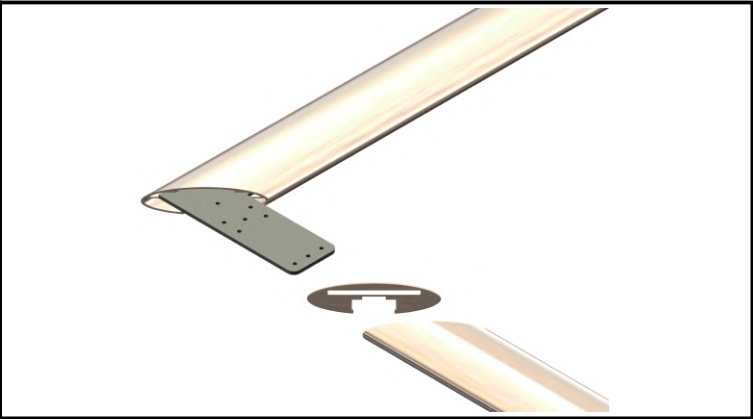

2) Slide the corner bracket into one of the handrails.

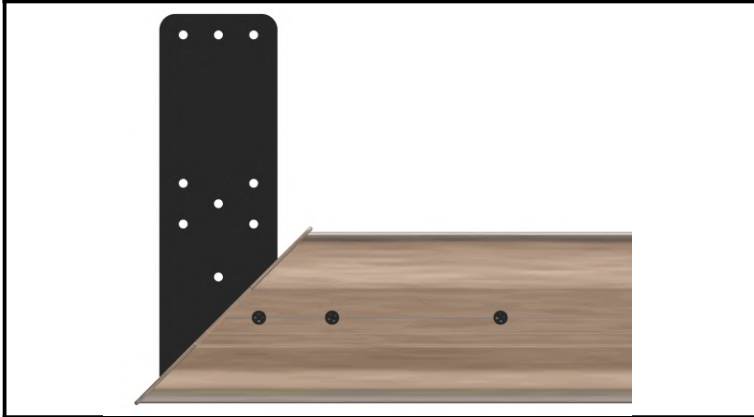

3) Tighten the screws.

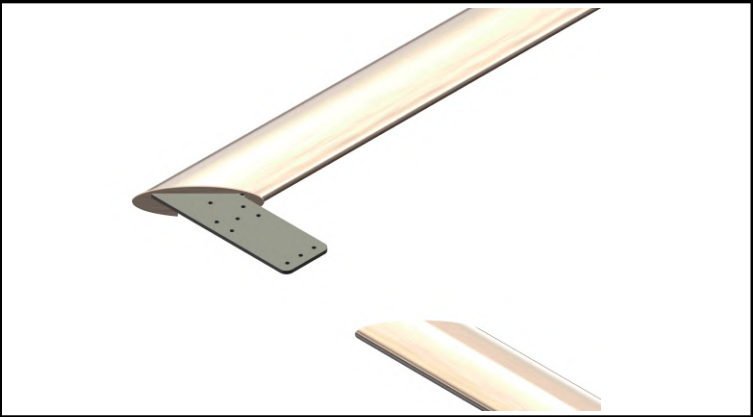

4) Slide the mitre protection plate onto the exposed corner bracket.

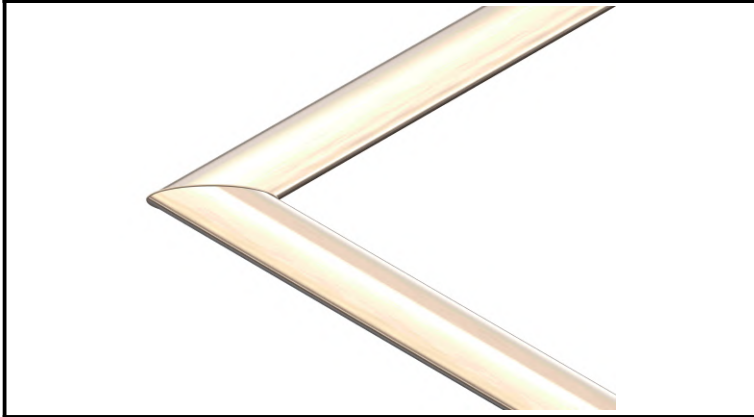

5) Slide the handrail onto the exposed corner bracket.



6) Tighten the screws. In this fashion assemble all the handrail parts and sections together.

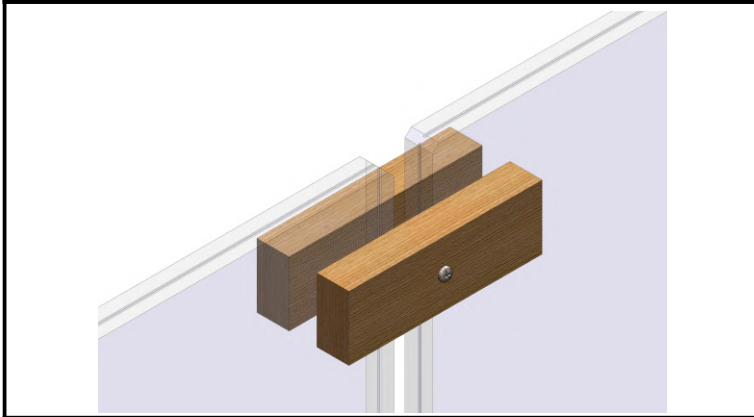

7) You can use two pieces of wood to clamp and align adjoining glasses together.

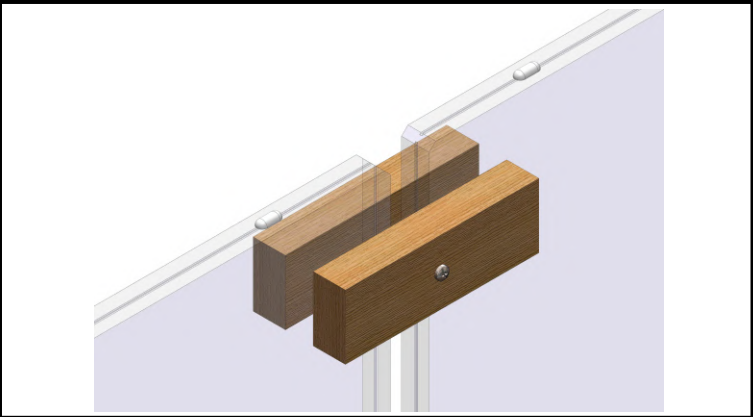

8) Apply a blob of silicone to the top of the glass panel 50mm in from the corner and then every 400 – 500mm as required (minimum 2 per glass).

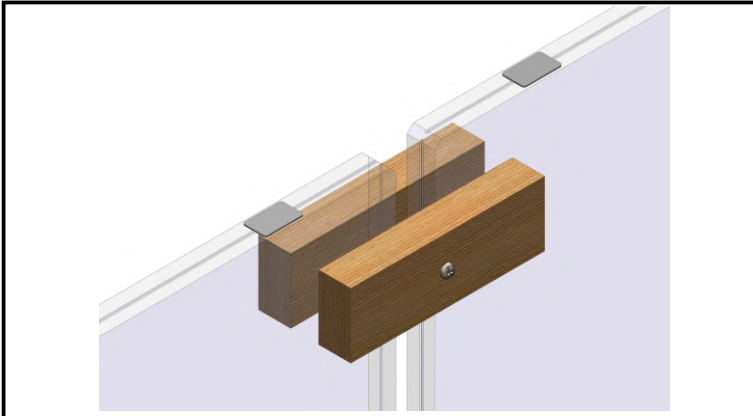

9) Place thin plastic packers onto the silicone.

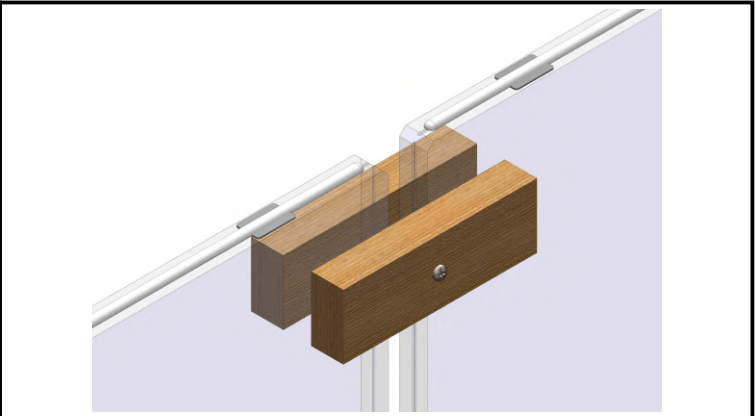

10) Apply a thick bead of silicone to the top of the glass panels.

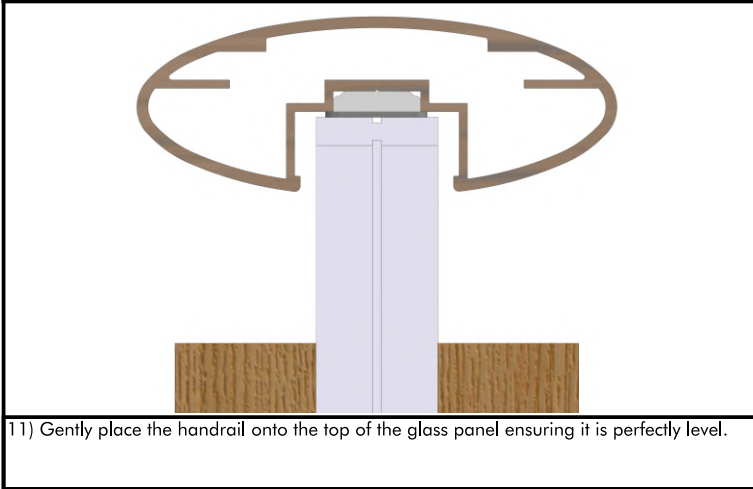

11) Gently place the handrail onto the top of the glass panel ensuring it is perfectly level.

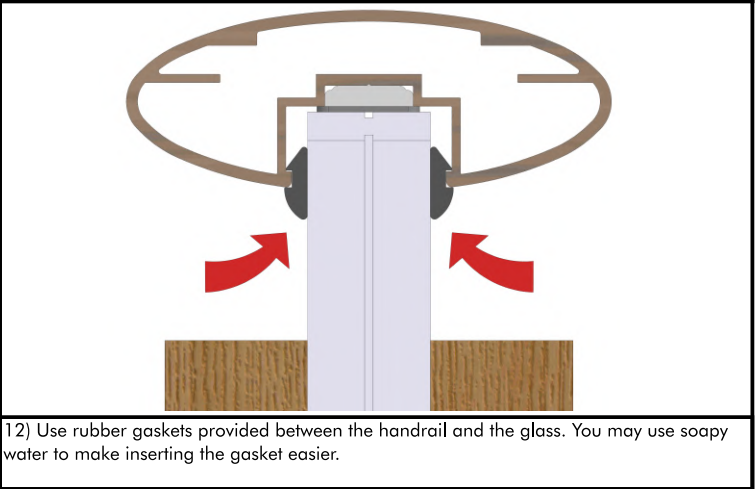

12) Use rubber gaskets provided between the handrail and the glass. You may use soapy water to make inserting the gasket easier.