



1ERSL\20465  
February 2013

# **ENGINEERS REPORTS & Surveys**

*The UK Network Engineers and Surveyors*

## **STRUCTURAL CALCULATIONS**

FOR

### **JULIET BALCONETTE SYSTEM**

**USING BALCONY 1 TYPE HANDRAIL  
WITHOUT INTERNAL REINFORCING BAR**

BY

### **BALCONY SYSTEMS LIMITED**

**Unit 6  
Systems House  
Eastbourne Road  
Blindly Heath  
Surrey  
RH7 6JP**



# ENGINEERS REPORTS & Surveys

*The UK Network Engineers and Surveyors*

1ERSL\20465  
February 2013

## BALCONY 1 SYSTEM HANDRAIL (without internal reinforcing bar)



Juliet Balconette, handrail in white – Portsmouth, Hampshire

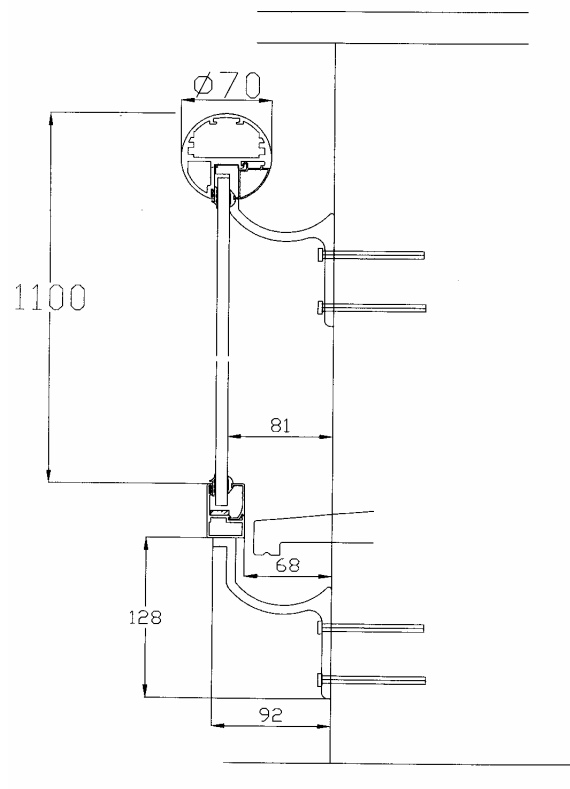



# ENGINEERS REPORTS & Surveys

*The UK Network Engineers and Surveyors*

1ERSL\20465  
February 2013

## BALUSTRADE LOADS:

The balustrade is designed to resist the horizontal imposed loads specified in **Table 4** of **BS 6399-1:1996** (see below), covering occupancy classes **A(i) and (ii), B(iii), (iv) and (v), C3(viii) and (ix), and (iii), (iv) and (iii).**

**Handrail:** The handrail is designed for a uniformly distributed horizontal imposed line load of 0.74 kN/m (164 pounds per metre approximately).

**Glass infill:** The glass infill is designed for a uniformly distributed load of 1.0 kN/m<sup>2</sup> (220 pounds per square metre approximately) plus a point load of 0.5 kN (110 pounds approximately).

**Table 4**  
**Minimum horizontal imposed loads for parapets, barriers and balustrades, etc.**

Type of occupancy for part of the building or structure	Examples of specific use	Horizontal uniformly distributed line load (kN/m)	A uniformly distributed load applied to the infill (kN/m <sup>2</sup> )	A point load applied to part of the infill (kN)
A Domestic and residential activities	(i) All areas within or serving exclusively one <b>[A1]</b> single family <b>[A1]</b> dwelling including stairs, landings, etc but excluding external balconies and edges of roofs (see C3 ix)	0.36	0.5	0.25
	(ii) Other residential, (but also see C)	0.74	1.0	0.5
B and E Offices and work areas not included elsewhere including storage areas	(iii) Light access stairs and gangways not more than 600mm wide	0.22	N/A	N/A
	(iv) Light pedestrian traffic routes in industrial and storage buildings except designated escape routes	0.36	0.5	0.25
	(v) Areas not susceptible to overcrowding in office and institutional buildings also industrial and storage buildings except as given above	0.74	1.0	0.5
C Areas where people may congregate C1/C2 Areas with tables or fixed seating	(vi) Areas having fixed seating within 530 mm of the barrier, balustrade or parapet	1.5	1.5	1.5
	(vii) Restaurants and bars	1.5	1.5	1.5
C3 Areas without obstacles for moving people and not susceptible to overcrowding	(viii) Stairs, landings, corridors, ramps	0.74	1.0	0.5
	(ix) External balconies and edges of roofs. Footways and pavements within building curtilage adjacent to basement/sunken areas	0.74	1.0	0.5
C5 Areas susceptible to overcrowding	(x) Footways or pavements less than 3 m wide adjacent to sunken areas	1.5	1.5	1.5
	(xi) Theatres, cinemas, discotheques, bars, auditoria, shopping malls, assembly areas, studio. Footways or pavements greater than 3 m wide adjacent to sunken areas	3.0	1.5	1.5
	(xii) <b>[A1]</b> Grandstands and stadia <b>[A1]</b>	See requirements of the appropriate certifying authority		
D Retail areas	(xiii) All retail areas including public areas of banks/building societies or betting shops. For areas where overcrowding may occur, see C5	1.5	1.5	1.5
F/G Vehicular	(xiv) Pedestrian areas in car parks including stairs, landings, ramps, edges or internal floors, footways, edges of roofs	1.5	1.5	1.5
	(xv) Horizontal loads imposed by vehicles	See clause 11		

**[A1] Not deleted [A1]**



# ENGINEERS REPORTS & Surveys

*The UK Network Engineers and Surveyors*

1ERSL\20465  
February 2013

## VERTICAL LOADS ON BALUSTRADES:

Amendment [A<sub>1</sub>] of BS 6399-1:1996 specifies that parapets, barriers and balustrades shall be designed for a vertical uniformly distributed imposed line load of 0.60 kN/m or a concentrated load of 1.0 kN, whichever gives the worst design condition in combination with the horizontal loading in Table 4.

Vertical loads on the handrail are transmitted through the 10mm thick safety glass and supported by the bottom rail brackets, except when the concentrated load is applied close to the end of the handrail, in which case the load is deemed to be shared between the top and bottom rail brackets in proportion to the stiffness of the two brackets.

## ALUMINIUM PROPERTIES:

Design standard = BS 8118:Part 1:1991 '*The Structural use of aluminium*'.

Handrail material = Extruded aluminium type 6063 T5

Bracket material = Extruded aluminium type 6063 T6

### Limiting stress for factored loads:

			<u>Type T5</u>	<u>Type T6</u>
Bending	$P_o$	=	110 N/mm <sup>2</sup>	160 N/mm <sup>2</sup>
Tension & compression	$P_a$	=	130 N/mm <sup>2</sup>	175 N/mm <sup>2</sup>
Shear	$P_v$	=	65 N/mm <sup>2</sup>	95 N/mm <sup>2</sup>

### Factored resistance capacity of a member:

Member capacity  $M_c$  = Calculated member capacity based upon the limiting stresses  $P_o$ ,  $P_a$  and  $P_v$  divided by the material factor  $\gamma_m$ .

Material factor  $\gamma_m$  = 1.20

### Factored loads:

Factored loads are used for checking the limit state of static strength of a member.

The imposed loads tabulated in BS 6988:1:1966 are known as 'service loads'. These loads are multiplied by a load factor  $\gamma_m$  of 1.33 (Table 3.1 of BS 8118:Part 1:1991) to give 'limit state' design loads that are used in relation to the factored resistance capacity of a member. The load factor applied to dead loads (self weight of members) is 1.2.

### Deflection:

All structural members deflect under load. For balustrade handrails the deflection is limited to 25mm under service load conditions.

Young's modulus for aluminium:  $E_a$  = 70,000 N/mm<sup>2</sup>



1ERSL\20465  
February 2013

## BALCONY 1 SYSTEM HANDRAIL (without internal reinforcing bar)

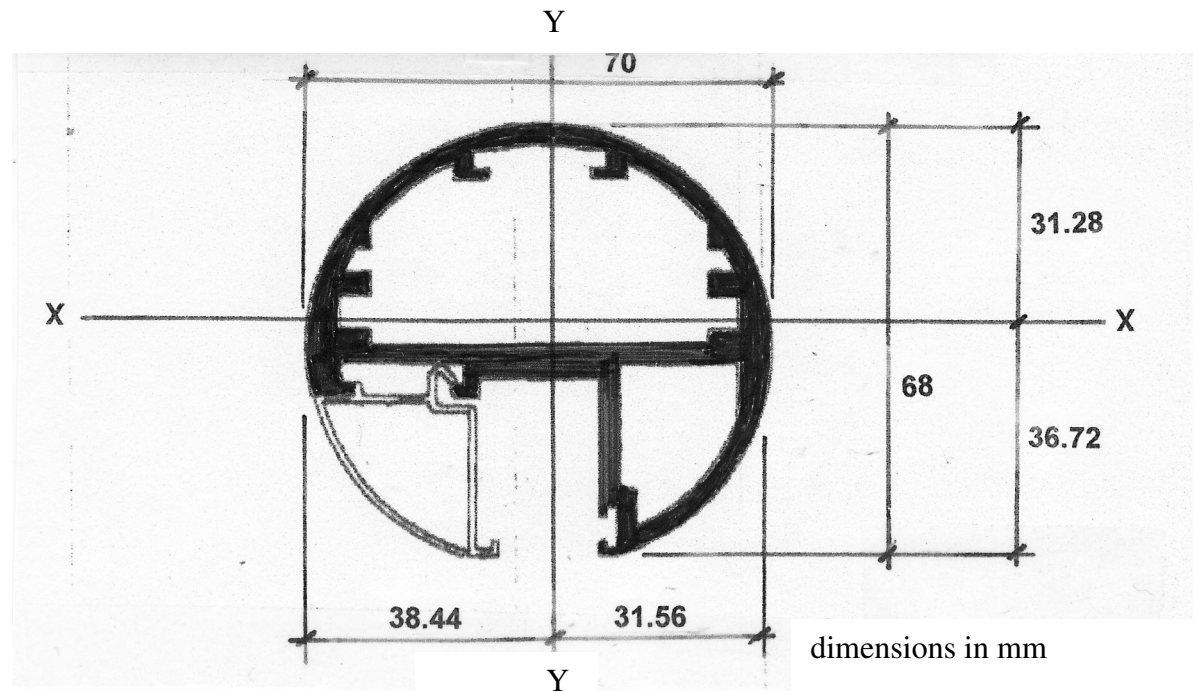

### Section properties:

Moment of inertia  
about the y-y axis =  $I_{yy}$  = 47 cm<sup>4</sup>

Least section modulus  
About the y-y axis =  $Z_{yy}$  = 12.227 cm<sup>3</sup>

Moment of inertia  
about the x-x axis =  $I_{xx}$  = 27.89 cm<sup>4</sup>

Least section modulus  
About the y-y axis =  $Z_{xx}$  = 7.595 cm<sup>3</sup>



1ERSL\20465  
February 2013

## BALCONY 1 SYSTEM HANDRAIL (without internal reinforcing bar)

### Moment capacity of the handrail:

$$\begin{aligned} \text{Moment capacity for horizontal loads} &= M_{rx} \\ &= \frac{(P_o) \times Z_{yy}}{(Y_m)} \\ &= \frac{110 \text{ N/mm}^2 \times 12.227 \text{ cm}^3 \times (10)^{-3}}{1.2} \\ &= \underline{1.12 \text{ kNm}} \end{aligned}$$

### Factored design loads:

$$\text{Factored horizontal UDL load on handrail} = 0.74 \text{ kN/m} \times (1.33) = 0.984 \text{ kN/m}$$

$$\text{Factored vertical UDL load on handrail} = 0.60 \text{ kN/m} \times (1.33) = 0.798 \text{ kN/m}$$

$$\text{Factored vertical point load on handrail} = 1.00 \text{ kN} \times (1.33) = 1.33 \text{ kN}$$

$$\begin{aligned} \text{Factored dead load on bottom rail} &= \text{weight of glass + aluminium elements} \times (1.2) \\ &= 0.26 \text{ kN/m} \times 1.2 \\ &= 0.312 \text{ kN/m} \end{aligned}$$

### Factored moments:

(based upon a span of 3.0m between the centres of supporting brackets)

$$\text{Horizontal moment on handrail} \quad M_x = \frac{0.984 \text{ kN/m} \times (3.0)^2}{8} = 1.107 \text{ kNm}$$

$$< 1.12 \text{ kNm} = \text{OK}$$

The handrail is adequate to support the design factored loads over a span of 3.0m between the centres of the handrail brackets.

- NOTE: a) The horizontal imposed load is resisted by the handrail alone.
- b) The vertical dead load is supported by the bottom rail alone.
- c) The vertical imposed loads are transmitted through the glass and are supported by the bottom rail brackets, except when the concentrated load is applied close to the end of the handrail, in which case the load is deemed to be carried by the top and bottom rail end brackets in combination.



1ERSL\20465  
February 2013

## BALCONY 1 SYSTEM HANDRAIL (without internal reinforcing bar)

$$\begin{aligned}
 \text{Service load deflection for the} &= \frac{5 w L^4}{384 E I_{yy}} \\
 \text{horizontal imposed load of} & \\
 \text{0.74 kN/m on a simply supported} & \\
 \text{span of 3.0m} &= \frac{5 (740 \times 3.0) (3000)^3}{384 \times 70000 \times 47 \times (10)^4} \\
 &= 23.72\text{mm} \\
 &< 25\text{mm} \quad \text{OK}
 \end{aligned}$$

## HANDRAIL BRACKETS:

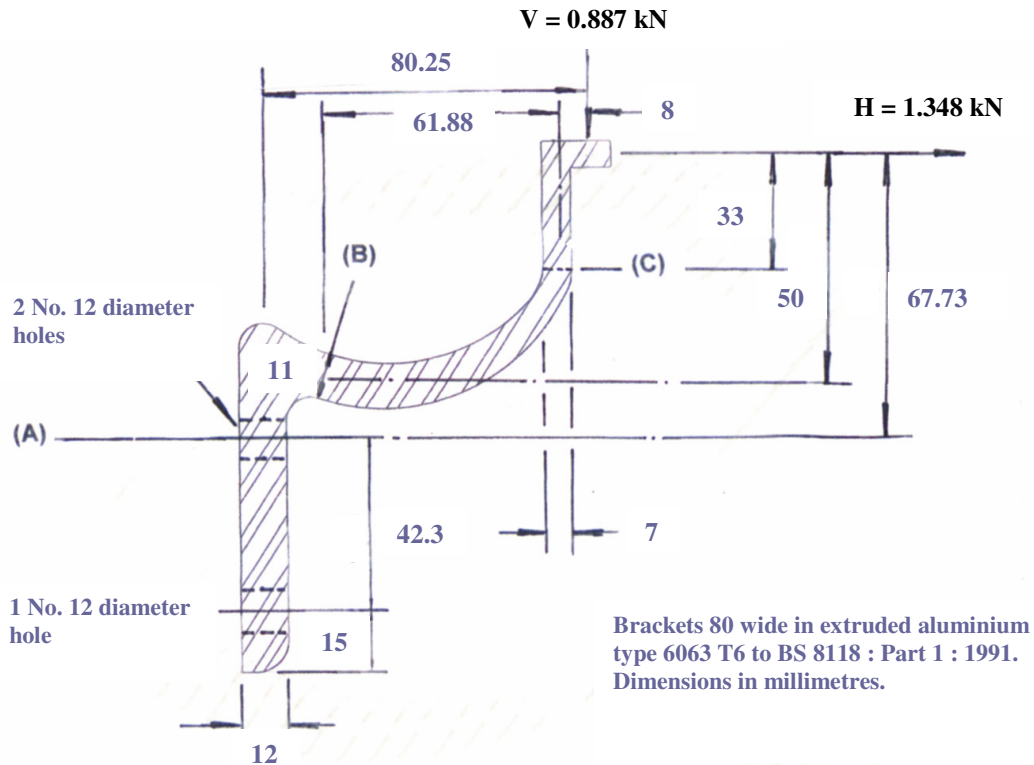

(factored loads based upon a span of 3.0m between the centres of brackets)

**Handrail brackets:** The horizontal imposed design load on the handrail can only act over the clear width of the opening, ie 2.74m. Bracket design load H calculated on this basis. The moment of inertia of the handrail bracket is 2 x that of the bottom rail bracket and will therefore support 2/3 of the vertical concentrated load when applied close to the end of the handrail.

$$\text{Horizontal load } H = 0.984 \text{ kN/m} \times \frac{2.74}{2} = 1.348 \text{ kN}$$

$$\text{Vertical load } V = 1.33 \text{ kN} \times \frac{2}{3} = 0.887 \text{ kN}$$





# ENGINEERS REPORTS & Surveys

*The UK Network Engineers and Surveyors*

1ERSL\20465  
February 2013

## Handrail brackets (continued)

### Section (A)

Dimensions at section (A) = 80mm wide x 12mm thick overall, less 2  
No 12mm diameter holes for 10mm  
diameter bolts.  
= 56mm x 12mm effective section.

Limiting stress in bending  $P_o$  = 160 N/mm<sup>2</sup>

Section modulus  $Z$  =  $\frac{56 \times (12)^2}{6}$  = 1344 mm<sup>3</sup>

Factored applied moment = (0.887 x 0.083) + (1.348 x 0.068)  
= 0.165 kNm

Moment capacity of section =  $\frac{(P_o) \times (Z)}{(m)}$   
=  $\frac{160 \text{ N/mm}^2 \times 1344 \text{ mm}^3 \times (10)^{-6}}{1.2}$   
= 0.178 kNm > 0.165 kNm

### Section (B)

Factored applied moment = (0.887 x 0.062) + (1.348 x 0.050)  
= 0.122 kNm

Section modulus  $Z$  =  $\frac{80 \times (11)^2}{6}$   
= 1613.33 mm<sup>3</sup>

Moment capacity of section =  $\frac{160 \text{ N/mm}^2 \times 1613.33 \text{ mm}^3 \times (10)^{-6}}{1.2}$   
= 0.215 kNm > 0.122 kNm

### Section (C)

Factored applied moment = (0.887 x 0.008) + (1.348 x 0.030)  
= 0.047 kNm

Section modulus  $Z$  =  $\frac{80 \times (7)^2}{6}$   
= 653.33 mm<sup>3</sup>

Moment capacity of section =  $\frac{160 \text{ N/mm}^2 \times 653.33 \text{ mm}^3 \times (10)^{-6}}{1.2}$   
= 0.087 kNm > 0.047 kNm

Shear force at Section (B) = 1.348 + 0.887  
= 2.235 kN

Average shear stress =  $\frac{2235}{80 \times 11}$  = 2.54 N/mm<sup>2</sup>  
which is low

**The handrail brackets are adequate to resist the design bending and shear forces.**





# ENGINEERS REPORTS & Surveys

*The UK Network Engineers and Surveyors*

1ERSL\20465  
February 2013

**Lower rail brackets:** These brackets have the same sectional profile as the handrail brackets but are 40mm wide instead of 80mm. Allowing for 1 No. 12mm diameter hole for a 10mm diameter bolt the effective width of the vertical leg is 28mm. The section modulus and moment capacity of the brackets is therefore half that of the handrail brackets. The brackets are installed at 500mm nominal maximum centres.

**Intermediate brackets:** Factored loads @ 500mm nominal spacing.

UDL imposed load	=	0.798 kN/m	=	0.399 kN/bracket
Concentrated imposed load spread through the glass onto a minimum of 3 No. brackets	=	1.33/3	=	0.443 kN/bracket
Dead load from glass + rails	=	0.312 kN/m	=	0.156 kN/bracket
Therefore maximum vertical load per bracket	=	0.443 + 0.156	=	0.599 kN/bracket
		say	=	0.60 kN/bracket

Factored moments:

<u>Section (A)</u>	<b>BM</b>	=	0.60 x 0.08	=	0.048 kNm	
	<b>Mc</b>	=	0.178/2	=	0.089 kNm	OK
<u>Section (B)</u>	<b>BM</b>	=	0.60 x 0.062	=	0.037 kNm	
	<b>Mc</b>	=	0.215/2	=	0.107 kNm	OK
<u>Section (C)</u>	<b>BM</b>	=	0.60 x 0.008	=	0.0048 kNm	
	<b>Mc</b>	=	0.087/2	=	0.0435 kNm	OK

**The brackets are adequate**

**End brackets:** Factored loads:

1/3 of the concentrated imposed vertical load when applied close to the end of the handrail	=	1.33/3	=	0.443 kN/bracket
Dead load from glass + rails	=	0.312 kN/m	=	0.078 kN/bracket
Σ vertical load per bracket	=	0.443 + 0.078	=	0.521 kN/bracket

This is slightly less than the design factored load of 0.60 kN/bracket for the intermediate brackets. The end brackets are of similar width and section profile and will therefore also be adequate.

**The brackets are adequate to resist the design bending and shear forces.**



# ENGINEERS REPORTS & Surveys

*The UK Network Engineers and Surveyors*

1ERSL\20465  
February 2013

## Fixing bracket bolt forces:

Top rail brackets (2 No bolts top; 1 No bolt bottom of bracket)

Moments taken about the lower bolt for the direct pull-out force on the top 2 No bolts:  
Factored loads on the bracket on page 8 are H = 1.348 kN V = 0.887 kN

$$\begin{aligned} \text{Direct tension on top 2 bolts} &= \frac{(1.348 \times 0.110) + (0.887 \times 0.08)}{0.042} \\ &= 5.22 \text{ kN} \\ &= 2.61 \text{ kN/bolt} \end{aligned}$$

$$\begin{aligned} \text{say} &= 2.70 \text{ kN/bolt (factored load)} \\ &= 2.03 \text{ kN/bolt (working load)} \end{aligned}$$

$$\begin{aligned} \text{Shear force on 3 No bolts} &= 0.887 \text{ kN (factored load)} \\ &= 0.296 \text{ kN/bolt} \end{aligned}$$

$$\begin{aligned} \text{say} &= 0.30 \text{ kN/bolt (factored load)} \\ &= 0.23 \text{ kN/bolt (working load)} \end{aligned}$$

Bottom rail brackets (2 No bolts top; 1 No bolt bottom of bracket)

$$\text{Vertical load on bracket } V = 0.60 \text{ kN (factored load)}$$

$$\text{Direct tension on top 2 bolts} = \frac{(0.60 \times 0.08)}{0.042}$$

$$\begin{aligned} &= 1.14 \text{ kN} \\ &= 0.57 \text{ kN/bolt ie, less than for top} \\ &\quad \text{bracket. Use the higher} \\ &\quad \text{forces for both top and} \\ &\quad \text{bottom brackets} \end{aligned}$$

$$\begin{aligned} \text{say} &= 2.70 \text{ kN (factored load)} \\ &= 2.03 \text{ kN (working load)} \end{aligned}$$

$$\begin{aligned} \text{Shear force on 3 No bolts} &= 0.20 \text{ kN/bolt (factored load)} \\ &= 0.16 \text{ kN/bolt (working load)} \end{aligned}$$

Assuming ave.  $\gamma$  of 1.25

These are relatively modest bolt forces that should be readily achievable with suitable drilled resin anchor bolts or similar into sound structure.



## SUMMARY

### **Juliet Balconette system using Balcony 1 type handrail And bottom rail without internal reinforcing bar**

1. The Juliet Balconette System, comprising Balcony 1 type handrails and bottom rails in extruded aluminium grade 6063 T5, is adequate to support the horizontal and vertical imposed loads specific in BS 6399-1:1996 in respect of the occupancy classes listed on page 3, for spans of up to 3.0 metres between the centres of supporting brackets.
2. The supporting brackets in extruded aluminium grade 6063 T6 are adequate to support the specified loads for spans up to 3.0 metres between bracket centres.
3. For the design loading, span and supporting bracket profile, the calculated working load direct pull-out force on each of the top 2 No bolts on the handrail brackets is 2.03 kN. The calculated loads on the bottom rail brackets are slightly less, but are assumed to be the same for design purposes.
4. The calculated working load shear force on each bolt on the top brackets is 0.23 kN. The calculated shear force on the bolts on the bottom rail brackets are slightly less, but are assumed to be the same for design purposes.
5. These are relatively modest bolt forces that should be readily achievable with suitable resin anchor bolts or similar into a sound structure.

However, the installers should satisfy themselves that the fixings chosen are suitable to resist these working load forces and also that the wall/structure into which the bolts are installed can safely support these loads.

6. The comprehensive stress on the 10mm thick toughened safety glass panels is low and well within the allowable stress recommended by the manufacturer, Pilkington Glass Limited.

The toughened glass panels were also test loaded by an independent testing laboratory (Sandberg Consulting Engineers – report reference 26890/M) and found to be adequate to withstand the factored loads specified in relevant British Standards.

**END**