



ENGINEERS REPORTS & Surveys

The UK Network Engineers and Surveyors

1ERSL\20465
March 2013

STRUCTURAL CALCULATIONS

FOR

JULIET BALCONETTE SYSTEM

**USING BALCONY 2 TYPE HANDRAIL
WITHOUT INTERNAL REINFORCING BAR**

BY

BALCONY SYSTEMS LIMITED

**Unit 6
Systems House
Eastbourne Road
Blindly Heath
Surrey
RH7 6JP**



Balcony 2 System section

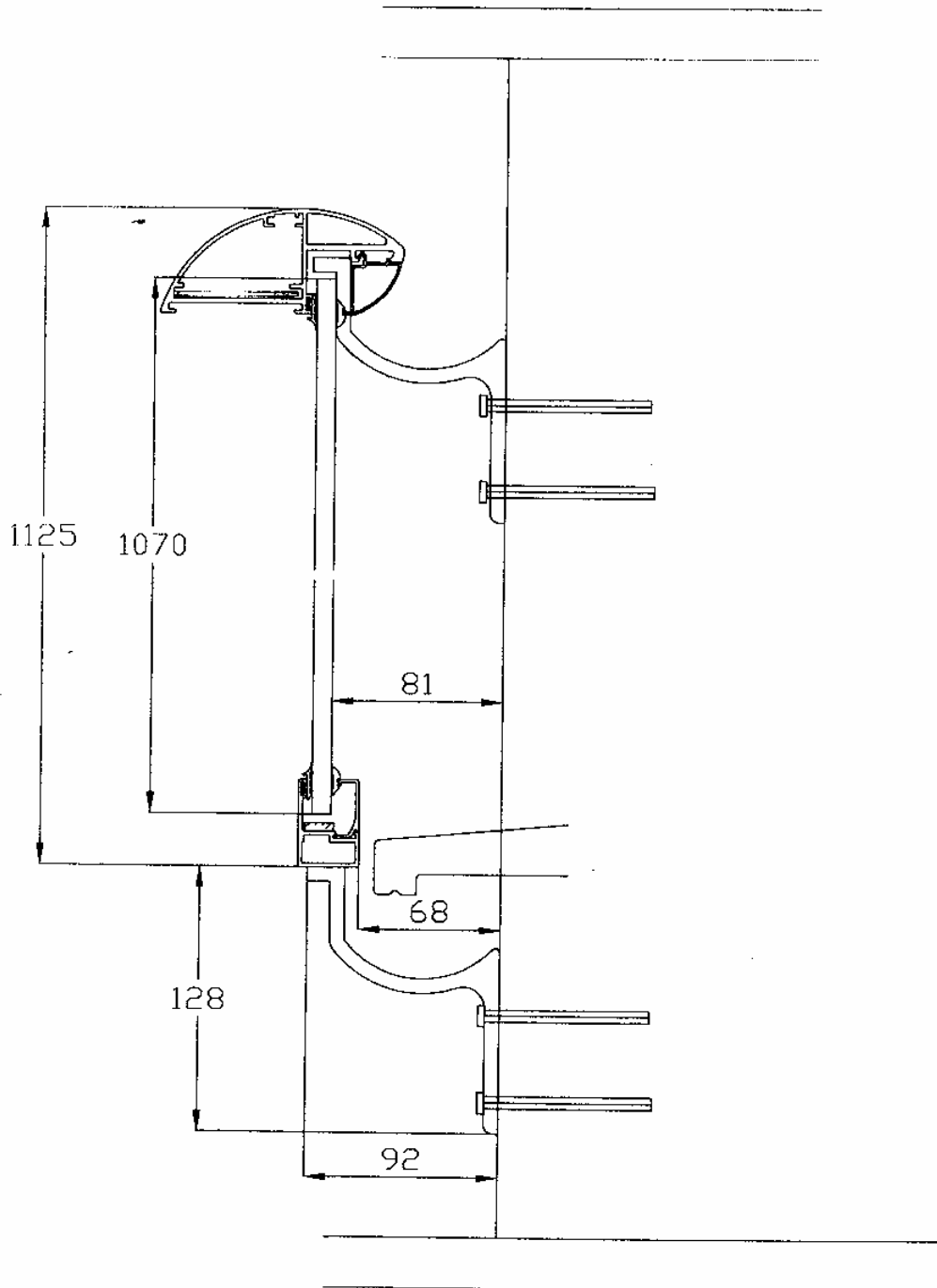



ENGINEERS REPORTS & Surveys

The UK Network Engineers and Surveyors

1ERSL\20465

March 2013

BALUSTRADE LOADS:

The balustrade is designed to resist the horizontal imposed loads specified in **Table 4** of **BS 6399-1:1996** (see below), covering occupancy classes **A(i) and (ii), B(iii), (iv) and (v), C3(viii) and (ix), and (iii), (iv) and (iii).**

Handrail: The handrail is designed for a uniformly distributed horizontal imposed line load of 0.74 kN/m (164 pounds per metre approximately).

Glass infill: The glass infill is designed for a uniformly distributed load of 1.0 kN/m² (220 pounds per square metre approximately) plus a point load of 0.5 kN (110 pounds approximately).

Table 4
Minimum horizontal imposed loads for parapets, barriers and balustrades, etc.

Type of occupancy for part of the building or structure	Examples of specific use	Horizontal uniformly distributed line load (kN/m)	A uniformly distributed load applied to the infill (kN/m ²)	A point load applied to part of the infill (kN)
A Domestic and residential activities	(i) All areas within or serving exclusively one [A1] single family [A1] dwelling including stairs, landings, etc but excluding external balconies and edges of roofs (see C3 ix)	0.36	0.5	0.25
	(ii) Other residential, (but also see C)	0.74	1.0	0.5
B and E Offices and work areas not included elsewhere including storage areas	(iii) Light access stairs and gangways not more than 600mm wide	0.22	N/A	N/A
	(iv) Light pedestrian traffic routes in industrial and storage buildings except designated escape routes	0.36	0.5	0.25
	(v) Areas not susceptible to overcrowding in office and institutional buildings also industrial and storage buildings except as given above	0.74	1.0	0.5
C Areas where people may congregate C1/C2 Areas with tables or fixed seating	(vi) Areas having fixed seating within 530 mm of the barrier, balustrade or parapet	1.5	1.5	1.5
	(vii) Restaurants and bars	1.5	1.5	1.5
C3 Areas without obstacles for moving people and not susceptible to overcrowding	(viii) Stairs, landings, corridors, ramps	0.74	1.0	0.5
	(ix) External balconies and edges of roofs. Footways and pavements within building curtilage adjacent to basement/sunken areas	0.74	1.0	0.5
C5 Areas susceptible to overcrowding	(x) Footways or pavements less than 3 m wide adjacent to sunken areas	1.5	1.5	1.5
	(xi) Theatres, cinemas, discotheques, bars, auditoria, shopping malls, assembly areas, studio. Footways or pavements greater than 3 m wide adjacent to sunken areas	3.0	1.5	1.5
	(xii) [A1] Grandstands and stadia [A1]	See requirements of the appropriate certifying authority		
D Retail areas	(xiii) All retail areas including public areas of banks/building societies or betting shops. For areas where overcrowding may occur, see C5	1.5	1.5	1.5
F/G Vehicular	(xiv) Pedestrian areas in car parks including stairs, landings, ramps, edges or internal floors, footways, edges of roofs	1.5	1.5	1.5
	(xv) Horizontal loads imposed by vehicles	See clause 11		
[A1] Not deleted [A1]				



VERTICAL LOADS ON BALUSTRADES:

Amendment [A₁] of BS 6399-1:1996 specifies that parapets, barriers and balustrades shall be designed for a vertical uniformly distributed imposed line load of 0.60 kN/m or a concentrated load of 1.0 kN, whichever gives the worst design condition in combination with the horizontal loading in Table 4.

Vertical loads on the handrail are transmitted through the 10mm thick safety glass and supported by the bottom rail brackets, except when the concentrated load is applied close to the end of the handrail, in which case the load is deemed to be shared between the top and bottom rail brackets in proportion to the stiffness of the two brackets.

ALUMINIUM PROPERTIES:

Design standard	=	BS 8118:Part 1:1991 'The Structural use of aluminium'.
Handrail material	=	Extruded aluminium type 6063 T5
Bracket material	=	Extruded aluminium type 6063 T6

Limiting stress for factored loads:

			<u>Type T5</u>	<u>Type T6</u>
Bending	P_o	=	110 N/mm ²	160 N/mm ²
Tension & compression	P_a	=	130 N/mm ²	175 N/mm ²
Shear	P_v	=	65 N/mm ²	95 N/mm ²

Factored resistance capacity of a member:

Member capacity	M_c	=	Calculated member capacity based upon the limiting stresses P_o , P_a and P_v divided by the material factor γ_m .
Material factor	γ_m	=	1.20

Factored loads:

Factored loads are used for checking the limit state of static strength of a member.

The imposed loads tabulated in BS 6988:1:1966 are known as 'service loads'. These loads are multiplied by a load factor γ_m of 1.33 (Table 3.1 of BS 8118:Part 1:1991) to give 'limit state' design loads that are used in relation to the factored resistance capacity of a member. The load factor applied to dead loads (self weight of members) is 1.2.

Deflection:

All structural members deflect under load. For balustrade handrails the deflection is limited to 25mm under service load conditions.



1ERSL\20465
March 2013

Balcony 2 System handrail (without internal reinforcing bar)

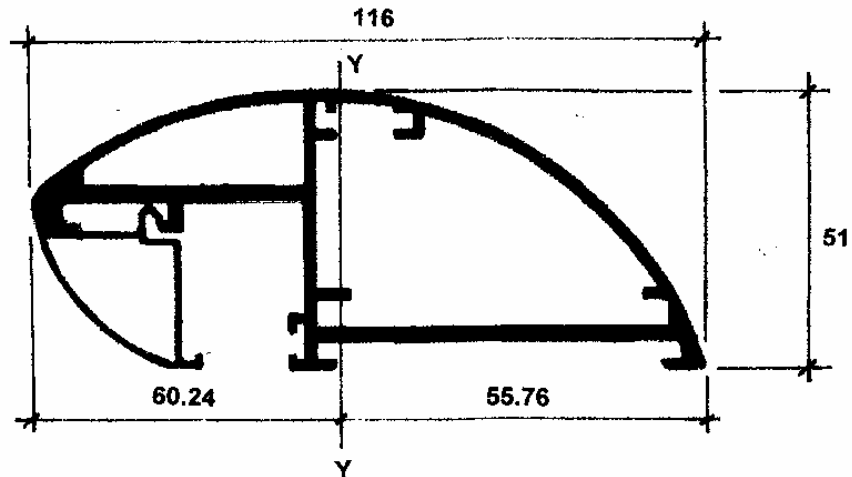

Dimensions in mm

Material and section properties:

Young's modulus of elasticity (aluminium) = E a
= 70000 N/mm²

Moment of inertia about the y-y axis = I_{yy}
= 87 cm⁴

Least section modulus about the y-y axis = Z_{yy}
= $\frac{87}{6.024}$
= 14.442 cm³



1ERSL\20465
March 2013

Balcony 2 System handrail (without internal reinforcing bar)

Moment capacity of the handrail:

$$\begin{aligned} \text{Moment capacity for} \\ \text{horizontal loads} &= M_{rx} \\ &= \frac{(P_o) \times Z_{yy}}{(\gamma_m)} \\ &= \frac{110 \text{ N/mm}^2 \times 14.442 \text{ cm}^3 \times (10)^{-3}}{1.2} \\ &= \underline{1.324 \text{ kNm}} \end{aligned}$$

Factored design loads:

$$\text{Factored horizontal UDL} \\ \text{load on handrail} = 0.74 \text{ kN/m} \times (1.33) = 0.984 \text{ kN/m}$$

$$\text{Factored vertical UDL} \\ \text{load on handrail} = 0.60 \text{ kN/m} \times (1.33) = 0.798 \text{ kN/m}$$

$$\text{Factored vertical point} \\ \text{load on handrail} = 1.00 \text{ kN} \times (1.33) = 1.33 \text{ kN}$$

$$\begin{aligned} \text{Factored dead load} \\ \text{on bottom rail} &= \text{weight of glass + aluminium elements} \times (1.2) \\ &= 0.26 \text{ kN/m} \times 1.2 \\ &= 0.312 \text{ kN/m} \end{aligned}$$

Factored moments: (based upon a span of 3.26 m between the centres of brackets)

$$\text{Horizontal moment} \quad M_x = \frac{0.984 \text{ kN/m} \times (3.26)^2}{8} = 1.307 \text{ kNm}$$

$$< 1.324 \text{ kNm} = \text{OK}$$

The handrail is adequate to support the design factored horizontal load over a span of 3.26 m between the centres of the handrail brackets.

- NOTE:
- The horizontal imposed load is resisted by the handrail alone.
 - The vertical dead load is supported by the bottom rail alone.
 - The vertical imposed loads are transmitted through the glass and are supported by the bottom rail brackets, except when the concentrated load is applied close to the end of the handrail, in which case the load is deemed to be carried by the top and bottom rail end brackets in combination.



Balcony 2 System handrail (without internal reinforcing bar)

$$\begin{aligned}
 \text{Service load deflection for the} &= \frac{5 w L^4}{384 E I_{yy}} \\
 \text{horizontal imposed load of} & \\
 \text{0.74 kN/m on a simply supported} & \\
 \text{span of 3.26 m} &= \frac{5 (740 \times 3.26) (3260)^3}{384 \times 70000 \times 87 \times (10)^4} \\
 &= 17.87\text{mm} \\
 &= \text{OK}
 \end{aligned}$$

HANDRAIL BRACKETS:

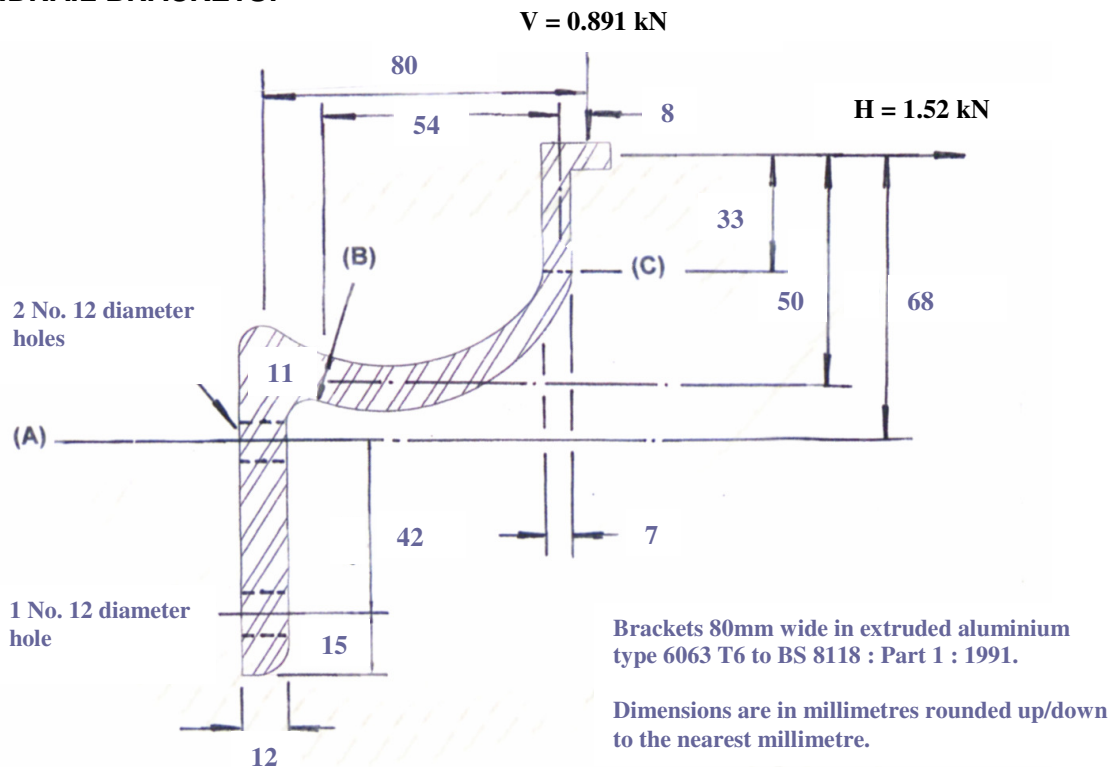

factored loads based upon a span of 3.26 m between the centres of brackets

Handrail brackets: The horizontal imposed design load on the handrail can only act over the clear width of the opening, ie 3.082 m. Bracket design load H calculated on this basis. The 2nd moment of inertia of the handrail bracket is 2 x that of the bottom rail bracket and will therefore support 67% of the vertical concentrated load when applied close to the end of the handrail.

$$\begin{aligned}
 \text{Horizontal load} \quad H &= 0.984 \text{ kN/m} \times \frac{3.082}{2} = 1.52 \text{ kN} \\
 \text{Vertical load} \quad V &= 1.33 \text{ kN} \times 67\% = 0.891 \text{ kN}
 \end{aligned}$$



1ERSL\20465
March 2013

Handrail brackets (continued)

Section (A)

Dimensions at section (A) = 80mm wide x 12mm thick overall, less
2 No 12mm diameter holes for 10mm
diameter bolts.
= 56mm x 12mm effective section.

Limiting stress in bending P_o = 160 N/mm²

Section modulus Z = $\frac{56 \times (12)^2}{6}$ = 1344 mm³

Factored applied moment = (0.891 x 0.08) + (1.52 x 0.068)
= 0.175 kNm

Moment capacity of section = $\frac{(P_o) \times (Z)}{(Y_m)}$
= $\frac{160 \text{ N/mm}^2 \times 1344 \text{ mm}^3 \times (10)^{-6}}{1.2}$
= 0.179 kNm > 0.175 kNm OK

Section (B)

Factored applied moment = (0.891 x 0.062) + (1.52 x 0.050)
= 0.131 kNm

Section modulus Z = $\frac{80 \times (11)^2}{6}$
= 1613 mm³

Moment capacity of section = $\frac{160 \text{ N/mm}^2 \times 1613 \text{ mm}^3 \times (10)^{-6}}{1.2}$
= 0.215 kNm > 0.131 kNm OK

Section (C)

Factored applied moment = (0.891 x 0.008) + (1.52 x 0.033)
= 0.057 kNm

Section modulus Z = $\frac{80 \times (7)^2}{6}$
= 653 mm³

Moment capacity of section = $\frac{160 \text{ N/mm}^2 \times 653 \text{ mm}^3 \times (10)^{-6}}{1.2}$
= 0.087 kNm > 0.057 kNm

Shear force at Section (B) = 1.52 + 0.891
= 2.411 kN

Average shear stress = $\frac{2411}{80 \times 11}$ = 2.74 N/mm²
which is low

The handrail brackets are adequate to resist the design bending and shear forces.



ENGINEERS REPORTS & Surveys

The UK Network Engineers and Surveyors

1ERSL\20465
March 2013

Lower rail brackets: These brackets have the same sectional profile as the handrail brackets but are 40mm wide instead of 80mm. Allowing for 1 No. 12mm diameter hole for a 10mm diameter bolt the effective width of the vertical leg is 28mm. The section modulus and moment capacity of the brackets is therefore 0.5 x that of the handrail brackets. The brackets are installed at 500mm nominal maximum centres.

Intermediate brackets: Factored loads @ 500mm nominal spacing.

UDL imposed load	=	0.798 kN/m	=	0.399 kN/bracket
Concentrated imposed load spread through the glass onto a minimum of 3 No. brackets	=	1.33/3	=	0.443 kN/bracket
Dead load from glass + rails	=	0.312 kN/m	=	0.156 kN/bracket
Therefore maximum vertical load per bracket	=	0.443 + 0.156	=	0.599 kN/bracket
		say	=	0.60 kN/bracket

Factored moments:

<u>Section (A)</u>	BM	=	0.60 x 0.08	=	0.048 kNm	
	Mc	=	0.175 x 0.5	=	0.088 kNm	OK
<u>Section (B)</u>	BM	=	0.60 x 0.062	=	0.037 kNm	
	Mc	=	0.215 x 0.5	=	0.107 kNm	OK
<u>Section (C)</u>	BM	=	0.60 x 0.008	=	0.0048 kNm	
	Mc	=	0.087 x 0.5	=	0.0435 kNm	OK

The brackets are adequate

End brackets: Factored loads:

33% of the concentrated imposed vertical load when applied close to the end of the handrail	=	1.33 x 0.33	=	0.439 kN/bracket
Dead load from glass + rails	=	0.312 kN/m	=	0.078 kN/bracket
Σ vertical load per bracket	=	0.439 + 0.078	=	0.517 kN/bracket

This is less than the design factored load of 0.60 kN/bracket for the intermediate brackets. The end brackets are of similar width and section profile and are therefore also adequate.

The bottom rail brackets are adequate.



Balcony 2 System handrail (without internal reinforcing bar)

Fixing bracket bolt forces: based upon a span of 3.26 m between the centre of handrail brackets and bottom rail brackets at 500mm nominal centres.

Top rail brackets (2 No bolts top; 1 No bolt bottom of bracket)

Moments taken about the lower bolt for the direct pull-out force on the top 2 No bolts:
Factored loads on the bracket shown on page 7 are H = 1.52 kN V = 0.891kN

$$\begin{aligned} \text{Direct tension on top bolt} &= \frac{(1.52 \times 0.11) + (0.891 \times 0.086)}{0.042} \\ &= 5.81 \text{ kN} \\ &= 2.90 \text{ kN/bolt} \end{aligned}$$

$$\begin{aligned} \text{say} &= 3.00 \text{ kN/bolt (factored load)} \\ &= 2.26 \text{ kN/bolt (working load)} \end{aligned}$$

$$\begin{aligned} \text{Shear force on 3 No bolts} &= 0.891 \text{ kN (factored load)} \\ &= 0.297 \text{ kN/bolt} \end{aligned}$$

$$\begin{aligned} \text{say} &= 0.30 \text{ kN/bolt (factored load)} \\ &= 0.23 \text{ kN/bolt (working load)} \end{aligned}$$

Bottom rail brackets (1 No bolt top; 1 No bolt bottom of bracket)

$$\text{Vertical load on bracket } V = 0.60 \text{ kN (factored load)}$$

$$\text{Direct tension on top 2 bolts} = \frac{(0.60 \times 0.086)}{0.042}$$

$$\begin{aligned} &= 1.23 \text{ kN} \\ &= \text{ie, less than for top bracket. Use the higher forces for both top and bottom brackets.} \end{aligned}$$

$$\begin{aligned} \text{say} &= 3.00 \text{ kN (factored load)} \\ &= 2.26 \text{ kN (working load)} \end{aligned}$$

$$\begin{aligned} \text{Shear force on 2 No bolts} &= 0.30 \text{ kN/bolt (factored load)} \\ &= 0.24 \text{ kN/bolt (working load)} \end{aligned}$$

Assuming ave. γ of 1.25

These are relatively modest bolt forces that should be readily achievable with suitable drilled resin anchor bolts or similar into sound structure.



SUMMARY

Juliet Balconette system using Balcony 2 type handrail without internal steel reinforcing bar

1. The Juliet Balconette System, comprising Balcony 2 type handrail in extruded aluminium grade 6063 T5, without steel reinforcing bar, is adequate to support the horizontal and vertical imposed loads specific in BS 6399-1:1996 in respect of the occupancy classes listed on page 3, for spans of up to 3.26 metres between the centres of supporting handrail brackets.
2. The supporting brackets in extruded aluminium grade 6063 T6 are adequate to support the specified loads for spans up to 3.26 metres between bracket centres.
3. The handrail and bottom rail brackets have the sectional profile shown on page 7. The handrail brackets are 80mm wide. The bottom rail brackets are 40mm wide and are installed at a maximum nominal spacing of 500mm.
4. For the design loading, span and supporting bracket profile, the calculated working load direct pull-out force on each of the top 2 No bolts on the handrail brackets is 2.26 kN. The calculated loads on the bottom rail brackets are slightly less, but are assumed to be the same for design purposes.
5. The calculated working load shear force on each bolt on the top brackets is 0.23 kN. The calculated shear force on the bolts on the bottom rail brackets is 0.24 kN.
6. These are relatively modest bolt forces that should be readily achievable with suitable resin anchor bolts or similar into a sound structure.

However, the installers should satisfy themselves that the fixings chosen are suitable to resist these working load forces and also that the wall/structure into which the bolts are installed can safely support these loads.

7. The compressive stress on the 10mm thick toughened safety glass panels is low and well within the allowable stress recommended by the manufacturer, Pilkington Glass Limited.

The toughened glass panels were also test loaded by an independent testing laboratory (Sandberg Consulting Engineers – report reference 26890/M) and found to be adequate to withstand the factored loads specified in relevant British Standards.

END