

Structural Calculations for BALCONY 2 system handrail with 58 x 4mm internal steel reinforcing bar using 60 x 24 RHS posts & 170 x 150 x 15 base plates

Our ref: B2WB6024150170BP261017

Date of issue: October 2017



Balcony 2 Balustrade fixed between two walls



Balcony 2 Balustrade on a 3 sided balcony with a central post

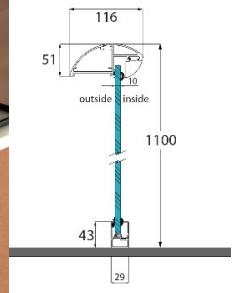

Balcony 2 section

DESIGN TO EUROCODES & CURRENT BRITISH STANDARDS

Design standards:

EN 1990	Eurocode 0:	Basis of structural design.
EN 1991	Eurocode 1:	Actions on structures.
EN 1993	Eurocode 3:	Design of steel structures.
EN 1999	Eurocode 9:	Design of aluminium structures.
BS EN 1990:2002 + A1:2005	Eurocode:	UK National annex for Eurocode
BS 6180:2011	British standard:	Barriers in and about buildings.

Design loads:

Occupancy class/es for which this design applies (Table 2: BS6180:2011) = Domestic and residential activities (i) & (ii)
Office and work areas not included elsewhere (iii), (iv) & (v)
Areas without obstacles for moving people and not susceptible to overcrowding (viii) & (ix)

Service load on handrail = Q_k = 0.74 kN/m uniformly distributed line load acting 1100mm above finished floor level. (Table 2: BS6180:2011)

Service load applied to the glass infill = Q_{k1} = A uniformly distributed load of 1.0 kN/m²

Point load on glass infill = point load = 0.50 kN applied to any part of the glass infill panels

Table 2 Minimum horizontal imposed loads for parapets, barriers and balustrades

Type of occupancy for part of the building or structure	Examples of specific use	Horizontal uniformly distributed line load (kN/m)	Uniformly distributed load applied to the infill (kN/m ²)	A point load applied to part of the infill (kN)
Domestic and residential activities	(i) All areas within or serving exclusively one single family dwelling including stairs, landings, etc. but excluding external balconies and edges of roofs	0.36	0.5	0.25
	(ii) Other residential, i.e. houses of multiple occupancy and balconies, including Juliette balconies and edges of roofs in single family dwellings	0.74	1.0	0.5
Offices and work areas not included elsewhere, including storage areas	(iii) Light access stairs and gangways not more than 600 mm wide	0.22	—	—
	(iv) Light pedestrian traffic routes in industrial and storage buildings except designated escape routes	0.36	0.5	0.25
	(v) Areas not susceptible to overcrowding in office and institutional buildings, also industrial and storage buildings except as given above	0.74	1.0	0.5
Areas where people might congregate	(vi) Areas having fixed seating within 530 mm of the barrier, balustrade or parapet	1.5	1.5	1.5
Areas with tables or fixed seatings	(vii) Restaurants and bars	1.5	1.5	1.5
Areas without obstacles for moving people and not susceptible to overcrowding	(viii) Stairs, landings, corridors, ramps	0.74	1.0	0.5
	(ix) External balconies including Juliette balconies and edges of roofs. Footways and pavements within building curtilage adjacent to basement/sunken areas	0.74	1.0	0.5

© BSI 2011 • 9

Table 2: BS6180:2011

- These loads are considered as three separate load cases. They are not combined.
- Factored loads are used for checking the limit state of static strength of a member.
- The service loads are multiplied by a partial factor for variable action $\gamma Q,1$ of 1.5 to give the ultimate design load for leading variable action.

Deflection:

- All structural members deflect to some extent under load. Service loads are used to calculate deflections.
- The total displacement of any point of a barrier from its original unloaded position under the action of service loads is limited to 25mm.

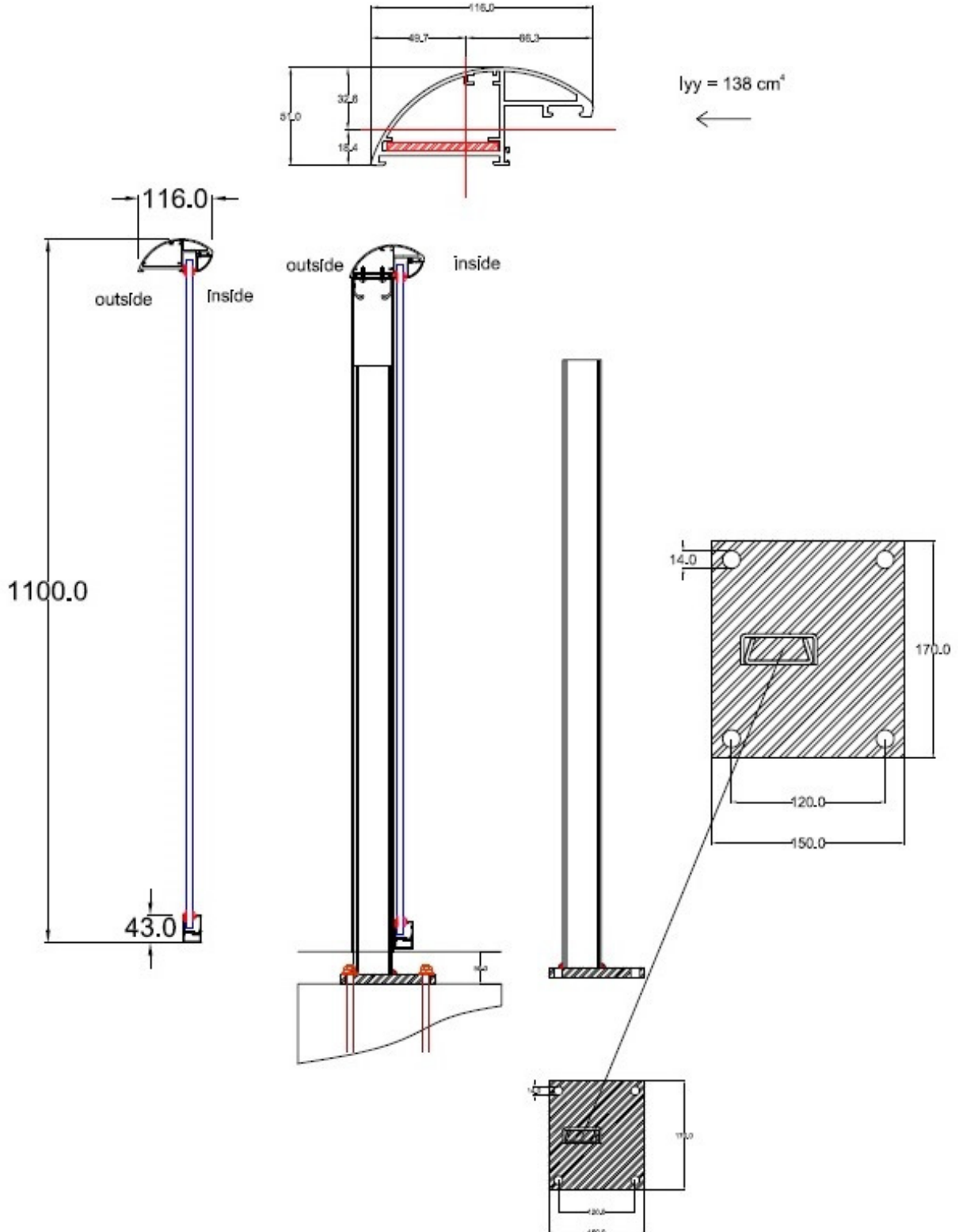

Section of Balcony 2 system, post and base plate details.

Balcony 2 system: Section properties of handrail:

Material type	=	Extruded aluminium type 6063 T5	
Characteristic 0.2% proof stress	=	f_o	= 130 N/mm ²
Characteristic ultimate tensile strength	=	f_u	= 175 N/mm ²
Modulus of elasticity	=	E	= 70 000 N/mm ²
Shear modulus	=	G	= 27 000 N/mm ²
Moment of inertia about the y-y axis	=	I_{yy}	= 138 cm ⁴
Least elastic modulus about the y-y axis	=	W_{el}	= 22.908 cm ³
Partial factor for material properties	=	γ_{M1}	= 1.10
Value of shape factor (conservative value)	=	α	= W_{pl}/W_{el} = 1.2 say
Design ultimate resistance to bending about the y-y axis	=	M_{Rd}	= $M_{o,Rd}$
	=	$\alpha W_{el} f_o / \gamma_{M1}$	
	=	$\frac{1.2 \times 22.908 \text{ cm}^3 \times 130 \text{ N/mm}^2 \times (10)^{-3}}{1.1}$	
	=	3.574 kNm	
Design ultimate horizontal load on handrail	=	F	= 0.74 kN/m x 1.5 = 1.11 kN/m
Design horizontal moment on handrail between points of support, assuming simply supported spans (worst case)	=	M	= $\frac{F L^2}{8}$
Allowable span L between points of support based upon the moment capacity of the handrail	=	$\left[\frac{8 \times M_{Rd}}{F} \right]^{0.5}$	
	=	$\left[\frac{8 \times 3.574 \text{ kNm}}{1.11} \right]^{0.5}$	
	=	5.075m	say = 5.0m

In terms of bending capacity the handrail can span up to 5.0m simply supported between points of support. However for a single span simply supported handrail the service load deflection is limited to a maximum of 25mm.

$$\text{Deflection } (\Delta) \text{ of a simply supported span (L) with an imposed UDL load (F)} \quad \Delta = \frac{5 F L^4}{384 E I}$$

$$\begin{aligned} \text{For a handrail span of 4.0m simply supported} \quad \Delta &= \frac{5 (740 \times 4.0) (4000)^3}{384 \times 70\,000 \times 138 \times (10)^4} \\ &= 25.53\text{mm} = \text{slightly} > 25\text{mm but say OK} \end{aligned}$$

Therefore deflection limitations govern the allowable simply supported span of the handrail.

In order that calculated service load deflection shall not exceed 25mm the allowable simply supported span of the handrail is limited to **4.0m**.

Vertical posts

On longer balconies posts are installed to support the handrail.

To allow for deflection of the posts, deflection of the handrail has to be limited so that the overall combined displacement of the handrail + post at any point of the barrier from its original unloaded position does not exceed 25mm.

$$\begin{aligned} \text{For a post spacing of 2.1m service load deflection of the handrail} \quad \Delta &= \frac{5 F L^4}{384 E I} \\ &= \frac{5 (740 \times 2.10) (2100)^3}{384 \times 70\,000 \times 138 \times (10)^4} \\ &= 1.94\text{mm} \end{aligned}$$

60 x 24mm RHS posts: properties of section:

The posts are made from 2 No. steel channels welded together to form a rectangular hollow section (RHS) measuring 60 x 24mm overall. To allow for the fact that the end flanges are not parallel, the post is assumed to be equivalent to a RHS with 3mm thick side walls and 5mm thick end walls.

Steel grade	=	S 275 to EN 10025
Nominal value of yield strength	=	$f_y = 275 \text{ N/mm}^2$
Nominal value of ultimate tensile strength	=	$f_u = 430 \text{ N/mm}^2$
Inertia of section about the y-y axis	=	$I_{xx} = 24.45 \text{ cm}^4$
Elastic modulus of section about the y-y axis	=	$W_{el} = 8.15 \text{ cm}^3$
Partial factor for material properties	=	$\gamma_{M1} = 1.10$
Partial factor for class 1 sections	=	$\gamma_{M0} = 1.00$
Modulus of elasticity	=	$E = 210\,000 \text{ N/mm}^2$
Shape factor W_{pl} / W_{el} (conservative value)	=	$\alpha = 1.2$

$$\begin{aligned} \text{Design ultimate resistance for bending about the x-x axis} \quad M_{pl,Rd} &= \frac{\alpha \times f_y \times W_{pl}}{\gamma_{M0}} \\ &= \frac{1.2 \times 275 \text{ N/mm}^2 \times 8.15 \text{ cm}^3 \times (10)^{-3}}{1.0} \\ &= 2.69 \text{ kNm} \end{aligned}$$

$$\begin{aligned} \text{Ultimate moment on post to top of base with posts at 2.1 m centres} \quad M_d &= (0.74 \times 2.10) \times 1.135 \times 1.5 \\ &= 2.65 \text{ kNm} < 2.69 \text{ kNm} \quad \text{OK} \end{aligned}$$

Service load deflection of post supporting 2.1m of handrail

$$\Delta = \frac{PL^3}{3EI}$$

$$= \frac{(740 \times 2.10) (1135)^3}{3 \times 210\,000 \times 24.45 \times (10)^4}$$

$$= 14.75\text{mm}$$

Combined total displacement of handrail + post from the original unloaded position (service loads)

$$\Delta t = 1.94\text{mm} + 14.75$$

$$= 16.69\text{mm} < 25\text{mm}$$

$$= \text{OK}$$

The Balcony 2 handrail with 58 x 4mm internal steel reinforcing bar, in conjunction with 60 x 24 RHS posts, is adequate to support the design loading on the handrail in terms of both strength and deflection limitations for posts spaced at up to 2.10 metre centres.

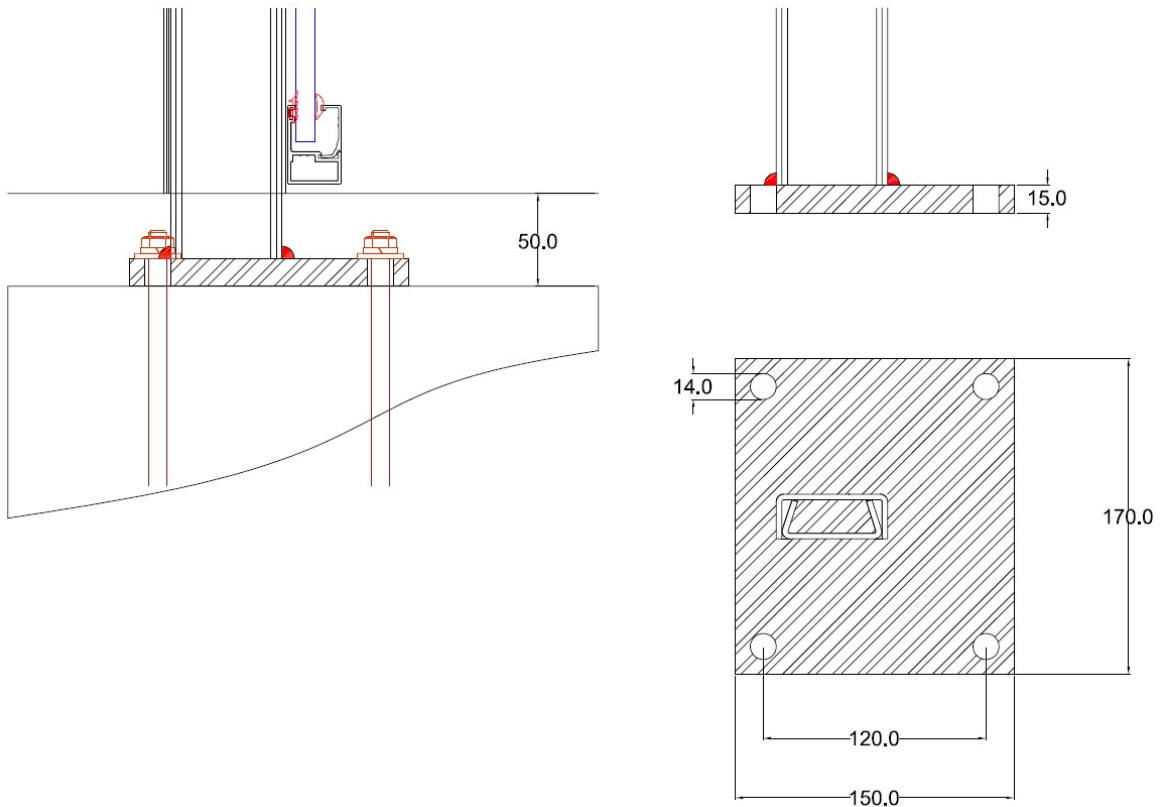

Baseplate size 170 x 150 x 15mm

Spacing of posts = 2.10 m

Design horizontal service load on handrail = 0.74 kN/m (acts outwards)

Ultimate design moment on posts to u/side base with posts at 2.1 m c/c = 0.74 kN/m x 1.5 x 2.10 x 1.15 = 2.68 kNm

Nominal ultimate load tension capacity of M12 (8.8 grade) bolts = 37.8 kN/bolt

Lever arm between the centres of bolts in tension and compression	=	120 mm	
Ultimate load bolt tension on 2 No. bolts	=	$\frac{2.68 \text{ kNm}}{2 \text{ No.} \times 0.12}$	= 11.17 kN/bolt
Working load bolt tension on 2 No. bolts	=	$\frac{11.17 \text{ kN}}{1.50}$	= 7.45 kN/bolt

BS 6180:2011, section 6.5, recommends that barrier fixings, attachments and anchorages should be designed to withstand a greater load than the design loading for the barrier generally. This is intended to ensure that under an extreme load condition, barriers show indications of distress by distortion, before there is any possibility of sudden collapse due to failure of the fixings. A 50% increase in the design load on fixings is recommended.

Applying the above recommendation, the ultimate bolt load becomes $11.17 \times 1.5 = 16.755 \text{ kN/bolt}$ (11.17 kN/bolt working load). A working load tension capacity of 11.17 kN/bolt should be within the capacity of M12 drilled resin anchor bolts into good quality concrete, or by drilling through and anchoring to the underside of a concrete slab.

The nominal tension capacity of M12 (8.8 grade) bolts is 37.80 kN/bolt. Higher bolt forces can therefore be achieved by direct bolting to a substantial steel frame.

Separate consideration is required where it is proposed to use other types of fixings, or where fixings are to be inserted into weaker materials.

Base plates: 170mm long x 150mm wide x 15mm thick.

Ultimate applied moment on posts at 2.1m maximum spacing	M_a	=	$(0.74 \times 1.5) \times 2.1 \times 1.15$	=	2.68 kNm
Plastic modulus of base 170mm wide x 15mm thick	W_{pl}	=	$\frac{170 \times (15)^2}{4}$	=	9562.5mm ³
Ultimate moment capacity of base	M_u	=	$\frac{275 \text{ N/mm}^2 \times 9562.5 \text{ mm}^3 \times (10)^{-6}}{1.0}$	=	2.63 kNm
		=	slightly < 2.68 kNm	but say	= OK

Welded connection between post & base plate

The 60 x 24mm RHS post is welded to the top of the base by means of a full strength butt and/or fillet weld.

Elastic section modulus of post	W_{el}	=	8.15 cm ³
Maximum ultimate elastic bending stress on post	$\frac{M_a}{W_{el}}$	=	$\frac{2.65 \times (10)^6}{8.15 \times (10)^3} = 325 \text{ N/mm}^2$
Transverse capacity of 10mm fillet weld		=	1.625 kN/mm on 5mm thick section 1.925 kN/mm

A continuous 10mm fillet weld around the perimeter of the post is adequate.

Balcony 2 system handrail: Glass infill

Design standard	=	Institution of Structural Engineers publication 'Structural use of glass in buildings (second edition) February 2014'.
Glass type	=	10mm thick thermally toughened soda silicate safety glass with smooth float 'as produced' finish with polished edges.
Characteristic design strength	=	120 N/mm ²
	$f_{g;d}$	$= \frac{K_{mod} \times K_{sp} \times K_{g;k}}{\gamma_{M;A}} + \frac{K_v (f_{b;k} - f_{g;k})}{\gamma_{M;V}}$
where:	K_{mod}	= 30 second load duration factor = 0.89 for a domestic balustrade load
	K_{sp}	= glass surface profile factor = 1.0 for float glass 'as produced'
	$f_{g;k}$	= characteristic strength of basic annealed glass = 45 N/mm ²
	K_v	= manufacturing process strengthening factor = 1.0 for horizontal toughening
	$f_{b;k}$	= characteristic bending strength of prestressed glass (120 N/mm ²)
	$\gamma_{M;A}$	= material partial factor = 1.6 for basic annealed glass
	$\gamma_{M;V}$	= material partial factor = 1.2 for surface prestressed (toughened) glass
Ultimate design stress	$f_{g;d}$	$= \frac{0.89 \times 1.0 \times 45}{1.6} + \frac{1.0 (120 - 45)}{1.2}$ = 87.53 N/mm²
Section modulus of glass 10mm thick	Z	$= \frac{1000 \times (10)^2}{6} = 16667 \text{ mm}^3/\text{m}$
Ultimate moment capacity of glass 1000mm wide x 10mm thick	Mu	$= f_{g;d} \times Z$ $= 87.53 \text{ N/mm}^2 \times 16667 \text{ mm}^3 \times (10)^{-6}$ $= 1.459 \text{ kNm/m}$

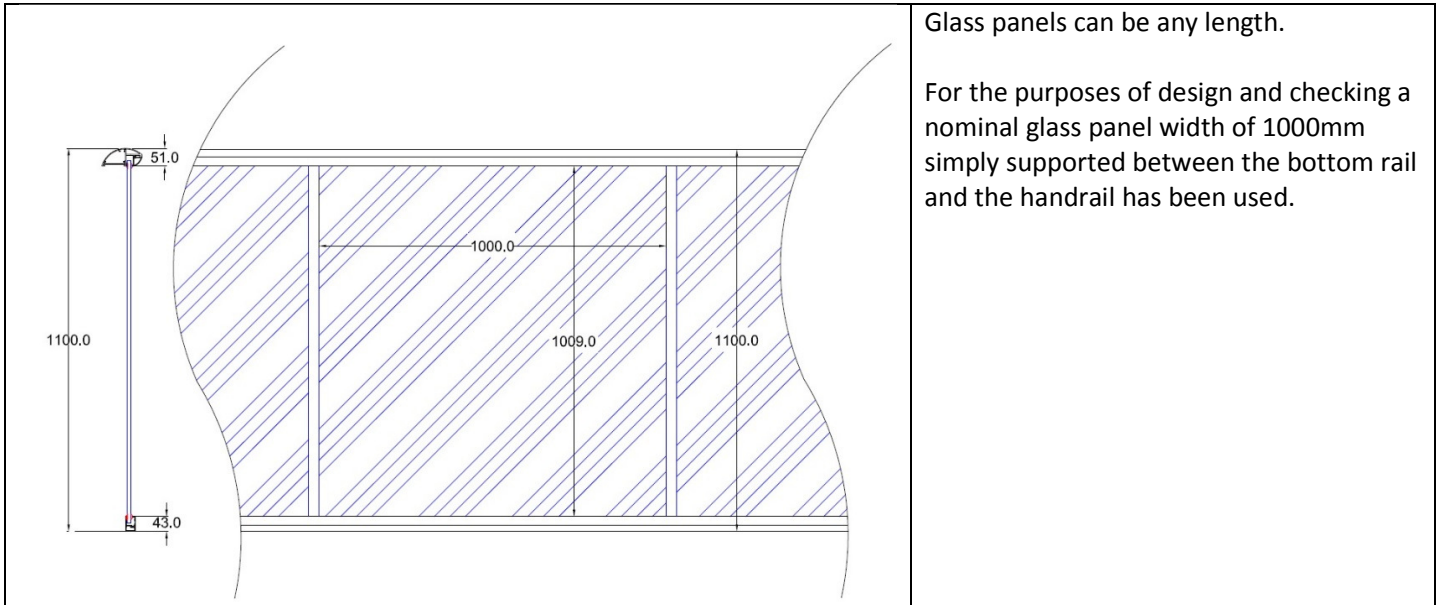

Glass panels can be any length.

For the purposes of design and checking a nominal glass panel width of 1000mm simply supported between the bottom rail and the handrail has been used.

Separate design loading conditions are considered:

Uniformly distributed load on the infill of 1.0 kN/m²

Ultimate UDL on glass $w = 1.0 \text{ kN/m}^2 \times 1.5 = 1.5 \text{ kN/m}^2$

Ultimate moment on glass due to UDL on span of 1.0m $M_u = \frac{1.5 \text{ kN/m}^2 \times (1.0)^2}{8} = 0.1875 \text{ kNm/m}$

$= < 1.459 \text{ kNm} = \text{OK}$

The reaction on the handrail from the uniformly distributed ultimate design load on the glass is less than the ultimate uniform horizontal design load on the handrail. Therefore the imposed UDL on the glass is not a critical design case in terms of stresses and displacements of the barrier system as a whole.

1. Point load on the infill of 0.5 kN

Point load on the glass = 0.5 kN point load applied in any position

Worst case for bending stress on the glass due to point load = point load applied at mid-height of glass

Ultimate moment on glass due to point load $= \frac{0.5 \text{ kN} \times 1.5 \times 1.0\text{m}}{4} = 0.1875\text{kNm}$

Conservatively, it is assumed that this bending moment is carried by a 300mm wide vertical strip of glass.

Moment capacity of 300mm strip $= 1.459 \text{ kNm} \times 0.3 = 0.4377 \text{ kNm}$
 $= > 0.1875\text{kNm} = \text{OK}$

The glass is adequate to support the ultimate design loading.



Glass deflection:

Consider service load deflection of the glass due to the design UDL:

$$\begin{aligned}
\text{Inertia of glass 10mm thick} &= \frac{1000 \times (10)^3}{12} &= & 83333 \text{ mm}^4 \\
\text{x 1000mm long} & & & \\
\text{Service load deflection} &= \frac{5 w L^4}{384 E I} \\
\text{due to a UDL of 1.0 kN/m}^2 & & & \\
\text{on a simply supported} &= \frac{5 \times (1000 \times 1.0) (1000)^3}{384 \times 70\,000 \times 83333} \\
\text{span of 1.0m} & & & \\
&= 2.232 \text{ mm} < \frac{\text{span}}{65} &= & \text{OK}
\end{aligned}$$

Conservatively, for deflection calculation purposes consider that the design point load is carried by a 300mm wide vertical strip of glass:

$$\begin{aligned}
\text{Inertia of glass 10mm thick} &= 0.3 \times 83333 \text{ mm}^4 &= & 25\,000 \text{ mm}^4 \\
\text{x 300mm long} & & & \\
\text{Service load deflection} &= \frac{P L^3}{48 E I} \\
\text{due to a point load of 0.5 kN} & & & \\
\text{applied at mid-span} &= \frac{500 \times (1000)^3}{48 \times 70\,000 \times 25\,000} \\
&= 5.95\text{mm} < \frac{\text{span}}{65} &= & \text{OK}
\end{aligned}$$

The glass is adequate in terms of both bending strength and deflection.

Wall fixings:

The handrail wall fixing consists of 3mm thick stainless steel angles bolted to the wall with 2 No. M8 stainless steel resin anchors or similar and secured to the handrail with 2 No. 4.8mm diameter stainless steel Phillips self-tapping screws.

The allowable simply supported span of the handrail between points of support is 4.0m.

$$\begin{aligned}
\text{Horizontal service (working)} &= 0.74 \text{ kN/m} \times 2.0\text{m} \\
\text{load on the wall fixing for a} &= 1.48 \text{ kN/fixing} \\
\text{span of 4.0m} &
\end{aligned}$$

There are two options for wall brackets; the standard wall bracket and the larger wall bracket. The larger wall bracket has a larger distance between the fixings and so allows a smaller load in the two bolts.

Standard Balcony 2 wall fixings:

The horizontal load on the handrail is applied to the fixing angles at the position of the Phillips screws located 30mm from the back of the angles. The wall fixing bolts are 34mm apart horizontally.

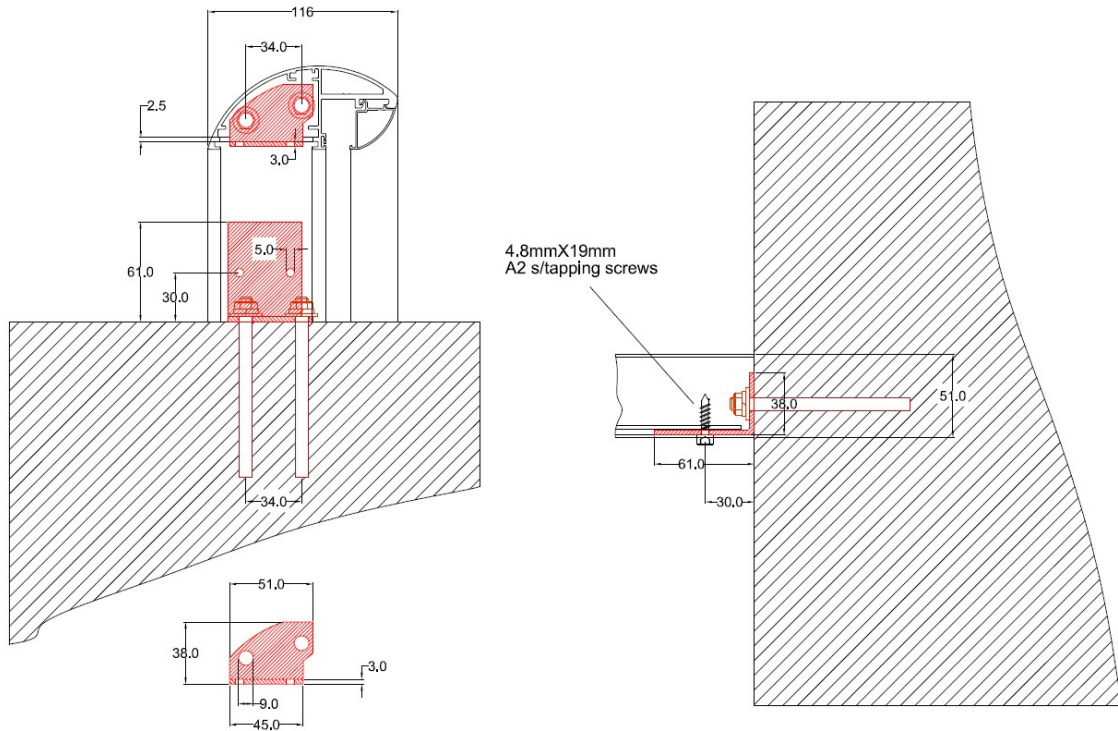

Pull-out forces on wall fixing

Working load pull-out force on the anchor bolts = $1.48 \text{ kN} \times \frac{30}{34}$ = 1.305 kN/bolt

Applying a 50% increase on fixing loads as recommended in BS 6180:2011, this becomes 1.958 kN/bolt.

For a handrail span of **4.0m** using the standard Balcony 2 wall bracket, the **working load** pull-out force on the wall fixing bolts is **1.958 kN/bolt**, including the 50% increase as per BS 6180.

Shear forces on wall fixings

Working load shear force on the anchor bolts and the 4.8mm x 19mm stainless steel self-tapping screws = 1.48 kN/2 = 0.74 kN/bolt

Applying a 50% increase on fixing loads as recommended in BS 6180:2011, this becomes 1.11 kN/bolt.

For a handrail span of **4.0m** using the standard Balcony 2 wall bracket, the **working load** shear force on the wall fixing bolts is **1.11 kN/bolt**, including the 50% increase as per BS 6180.

Ultimate load shear force on the anchor bolts and screws = $1.11 \text{ kN/bolt} \times 1.5$ = 1.665 kN/bolt or screw

Larger Balcony 2 wall fixings:

The horizontal load on the handrail is applied to the fixing angles at the position of the Phillips screws located 30mm from the back of the angles. The wall fixing bolts are 57mm apart horizontally.

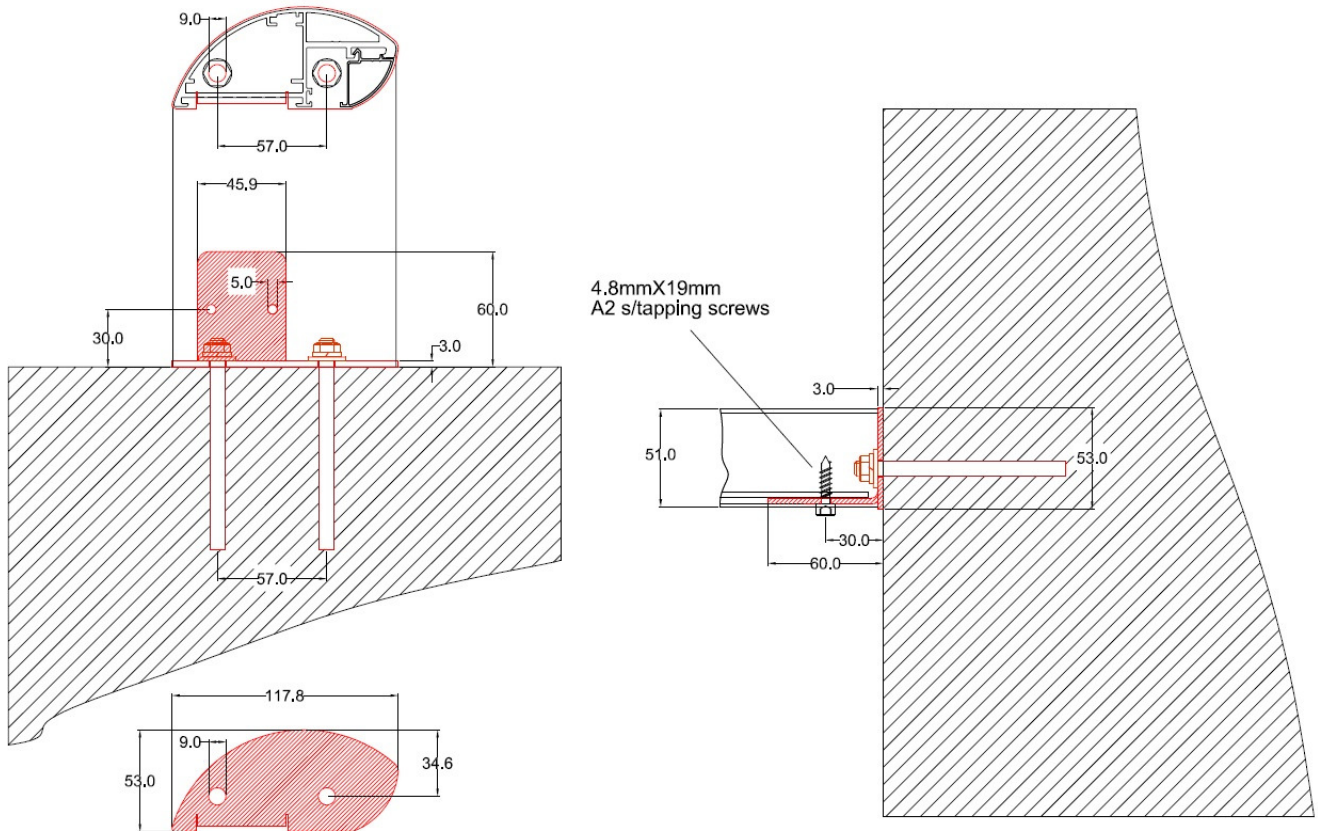

Pull-out forces on wall fixing

Working load pull-out force on the anchor bolts = $1.48 \text{ kN} \times \frac{30}{57}$ = 0.779 kN/bolt

Applying a 50% increase on fixing loads as recommended in BS 6180:2011, this becomes 1.169 kN/bolt, say 1.17 kN/bolt.

For a handrail span of **4.0m** using the standard Balcony 2 wall bracket, the **working load** pull-out force on the wall fixing bolts is **1.17 kN/bolt**, including the 50% increase as per BS 6180.

Shear forces on wall fixings

Working load shear force on the anchor bolts and the 4.8mm x 19mm stainless steel self-tapping screws = 1.48 kN/2 = 0.74 kN/bolt

Applying a 50% increase on fixing loads as recommended in BS 6180:2011, this becomes 1.11 kN/bolt.

For a handrail span of **4.0m** using the standard Balcony 2 wall bracket, the **working load** shear force on the wall fixing bolts is **1.11 kN/bolt**, including the 50% increase as per BS 6180.

Ultimate load shear force on the anchor bolts and screws = $1.11 \text{ kN/bolt} \times 1.5$ = 1.665 kN/bolt or screw

Phillips stainless steel self-tapping screws

Shearing force, construction screws

Dimensioning value F_{sd} kN/screw. Attention is paid both to failure of the edge of the hole and shearing failure in the screw. Safety class 1.

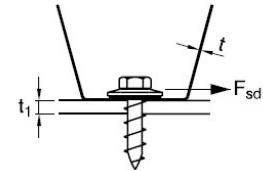

Nom t mm	When calculating t mm	Tensile yield limit N/mm ²	Screw diameter 4.2 mm		Screw diameter 4.8 mm		Screw diameter 5.5 mm		Screw diameter 6.3 mm							
			t ₁ = t	t ₁ = 2,5 t	t ₁ = t	t ₁ = 2,5 t	t ₁ = t	t ₁ = 2,5 t	t ₁ = t	t ₁ = 2,5 t						
0.4	0.32	250	0.26	0.54	0.28	0.61	0.30	0.70	0.32	0.81						
0.5	0.41	250	0.38	0.69	0.40	0.79	0.43	0.90	0.46	1.03						
0.6	0.52	250	0.52	0.86	0.56	0.98	0.60	1.12	0.64	1.29						
0.7	0.60	350	0.93	1.41	1.00	1.61	1.07	1.85	1.14	2.12						
0.8	0.73	350	1.25	1.72	1.34	1.96	1.43	2.25	1.53	2.58						
1.0	0.93	250	1.29	1.56	1.38	1.79	1.47	2.05	1.58	2.34						
1.0	0.93	350	1.80	2.19	1.93	2.50	2.06	2.86	2.21	3.28						
1.2	1.13	350	2.41	2.66	2.58	3.04	2.76	3.48	2.95	3.99						
1.5	1.42	250	2.39	2.39	2.60	2.73	2.78	3.12	2.97	3.58						
1.5	1.42	350	3.03*	3.03*	3.63	3.82	3.64	3.89	4.37	4.16	5.01					
2.0	1.91	350	3.03*	3.03*	4.16	3.64	4.16	3.64	5.72	5.20	5.72	5.20	6.49	6.74		
2.5	2.40	350	3.03*	3.03*	4.16	3.64	4.16	3.64	5.72	5.20	5.72	5.20	7.80	6.76	7.80	6.76

In the area of number pairs in the table and marked *, shearing failure in the screw is decisive.

The value to the left in each number pair relates to carbon steel screws, while the number to the right relates to stainless steel screws.

Excerpt of the table at the foot of page 7 of Lindab's literature headed 'Shearing force, construction screws'

- Material type = stainless steel grade 304
- Characteristic ultimate tensile strength = 621 N/mm²
- Characteristic 0.2% proof stress = 290 N/mm²

Phillips self-tapping screws: ultimate shear loads taken from the table in Lindab's technical literature.

Thickness of aluminium in the handrail at screw positions = 5.4mm

Thickness of stainless steel angle brackets (Nom t mm) = 3.0mm

Ultimate shear capacity of 4.8mm diameter screws, safety class 1 for Nom t = 2.5mm = 3.64 kN/screw (from Lindab's table)

For safety classes 2 and 3 this value is divided by 1.1 and 1.2 respectively. Safety class 3 is the highest safety class and has been assumed to apply to balustrades. The shear capacities given in Lindab's table are based upon material having a tensile yield limit of 350 N/mm². The values given in the table have been adjusted to allow for the yield stress of stainless steel type 304 (290 N/mm².)

The ultimate shear capacity of 3.64 kN/screw has therefore been reduced by 290/350 and divided by 1.2 to represent safety class 3 and 290 N/mm² yield stress rather than 350 N/mm². The adjusted ultimate shear capacity is then 2.51 kN/screw.

Ultimate shear force/screw on a simply supported span of 4.0m = 1.11 kN

Factor of safety against shear failure for a 4.8mm diam. screw = 2.51/1.11 = 2.26 = OK

Stainless steel brackets

The horizontal part of the bracket measures 45mm wide x 3mm thick.

Plastic modulus of 45 x 3mm section for horizontal loads = $\frac{3 \times (45)^2}{4}$ = 1519 mm³

Resistance moment of section for horizontal loads = 290 N/mm² x 1519 mm³ x (10)⁻⁶ = 0.44 kNm

For a simply supported span of 4.0m: ultimate load on end bracket = 1.48 x 1.5 = 2.22 kN

This load is applied 30mm from the rear face of the bracket.

Ultimate horizontal moment applied to the bracket on the maximum simply supported span of 4.0m = 2.22 x 0.03 = 0.067 kNm = < 0.44 kNm OK

Bottom rail fixing:

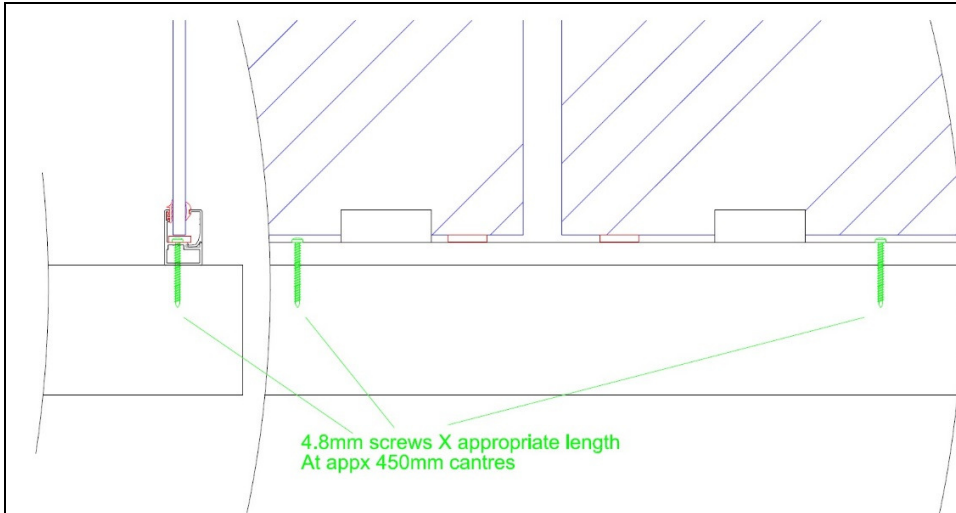

The standard bottom rail fixing consists of 4.8mm diameter screws at 450mm centres.

The worst case for design loading on the fixings is when the design service point load of 0.50 kN on the glass acts at the position of a fixing. The fixing screw is then subjected to a working load shear force of 0.50 kN/screw.

The allowable load on the fixing screws varies depending upon the type and thickness of the material into which the screws are inserted.

As an example, fixing to a balcony deck comprising 15mm thick plywood strength class C16, group 1, the basic allowable working load single shear value given in BS 5268 : Part 2 : 1996 for a No. 10 (4.88mm) screw 45mm long is 0.519 kN.

Where a pre-drilled steel component of adequate strength is screwed to a timber member, the basic lateral load of 0.519 kN is multiplied by a modification factor of 1.25, making an allowable shear value of 0.648 kN, which is adequate in relation to the design working shear load force of 0.50 kN.

Other values of allowable shear loads on fixings will apply where the deck material is of different strength and/or thickness.

The installers should satisfy themselves that the fixings chosen are adequate to resist the design loads in relation to the fixing material in each individual installation.

SUMMARYBALCONY 2 system handrail with 58 x 4mm steel internal reinforcing bar using 60 x 24mm RHS posts fitted to 170 x 150 x 15 base plates:

- 1) On single span and corner balconies, the handrail is capable of supporting the design factored loads over spans up to **4.0 metres** between points of support. (i.e. a handrail wall fixing, or a handrail corner joint.)
- 2) On longer balconies where the length of the balustrade exceeds 4.0 metres, vertical posts are installed at a maximum spacing of **2.1metres** between post centres. The posts are made from 60 x 24mm rectangular hollow steel sections (RHS) sheathed in aluminium.
- 3) The RHS posts are welded (full strength butt or 10mm fillet welds) to **170 x 150 x 15mm** steel base plates. 14mm diameter holes are provided for 4 No. M12 holding down bolts.
- 4) For the maximum span of 4.0 metres on single span and corner balconies, the horizontal working pull-out load on the wall fixing bolts is **2.0 kN/bolt** for the **standard** wall bracket, or **1.17 kN/bolt** for the **larger** wall bracket. The horizontal working shear load on the wall fixing bolts is **1.11 kN/bolt**. 9mm diameter holes are provided in wall fixing brackets for M8 drilled anchor bolts.
- 5) On longer balconies, where posts are installed at a maximum spacing of 2.1m, the design working load pull-out force on the holding down bolts is **11.17 kN/bolt**. This load should be achievable using M12 drilled resin anchor bolts into good quality concrete, or by drilling through and anchoring to the underside of a suitable concrete slab. Higher loads are achievable using M12 (8.8 grade) bolts connected direct to a substantial steel frame.
- 6) The design working loads specified above include a 50% increase on calculated loads, as recommended in BS 6180:2011.
- 7) The installers should satisfy themselves that the fixing bolts chosen are suitable to resist the specified loads, and also that the structure into which they are installed can support these loads.
- 8) The 4.8mm diameter self-tapping stainless steel screws connecting the handrail to the stainless steel angle brackets at wall and post fixings are adequate to support the design loads specified in relevant British and European Standards. The 3mm thick stainless steel brackets are also adequate to support these loads.
- 9) The standard bottom rail fixing comprises 4.8mm diameter screws inserted into the balcony deck at 450mm centres. At this spacing the fixings are required to have a working load shear capacity of 0.50 kN/screw. The installers should satisfy themselves that the screws chosen are suitable to resist this load when inserted into the particular deck material present on a specific project. Where the deck material is of reduced strength and/or thickness the spacing of the screws should be reduced accordingly.
- 10) The 10mm thick thermally toughened safety glass infill panels are adequate to support the design loads specified in the relevant British and European Standards.

**Prepared for and on behalf of Balconette by
A. G. Bice CEng, FICE, FStructE.**